

# COMSOL NEWS

A TECHNICAL COMPUTING MAGAZINE



## Lithium-Ion Battery Simulation for Greener Ford Vehicles

COVER STORY PAGE 8

**ENERGY:**  
WIND TURBINE  
NOISE  
DAMPENING

12

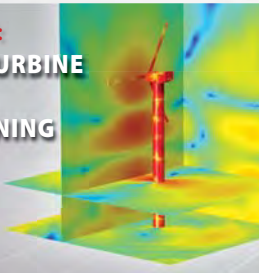

**AEROSPACE:**  
ATTITUDE CONTROL  
REACTION SPHERE

46

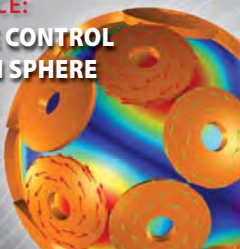

## Welcome to the COMSOL News for 2011!

In the following user stories, nineteen diverse high-tech organizations showcase how their adoption of COMSOL Multiphysics has led to new product designs and research findings.

Many of the stories in the COMSOL News are based on papers presented at the COMSOL Conferences last fall. The full papers are available on our website. Chances are good you'll find examples that apply directly to your current project. In fact, the archive of papers presently contains more than 1,800 fully documented modeling projects.

I also want to point out a fairly new avenue through which you connect with fellow COMSOL users: our online discussion forum. All day, every day, there are plenty of new postings with expert users online to answer questions and share their modeling skills. Feel free to join in and talk about modeling — visit [www.comsol.com/community/forum](http://www.comsol.com/community/forum).

Finally, I want to extend a big "thank you" to everyone who contributed articles for this issue of the COMSOL News.

Best regards,  
Bernt Nilsson  
Sr VP of Marketing



SCAN TO SHARE COMSOL NEWS 2011 WITH YOUR COLLEAGUES OR GO TO:  
[www.comsol.com/cn2011qr](http://www.comsol.com/cn2011qr)

### MULTIPHYSICS

- 4 Multiphysics Analysis of a Burning Candle
- 5 Capacitively Coupled Plasma Analysis

### HVAC

- 6 3D Direct Modeling Streamlines Micro-Cogeneration System Design and Analysis Processes

### AUTOMOTIVE

- 8 Lithium-Ion Battery Simulation for Greener Ford Vehicles

### ENERGY

- 12 Wind Turbine Noise Reduction
- 16 The Burning Need for Modeling
- 18 Sea Floor Energy Harvesting
- 20 Around the Clock Solar Power
- 24 Modeling Electromagnetic Waves in the Thermonuclear Fusion Plasmas of the MIT Alcator C-Mod Tokamak

### MEDICAL

- 29 Multiphysics Modeling Gives Developer of Small, Low-Power Biomedical Devices a Competitive Edge
- 34 Easy and Accurate Measurement of Blood Viscosity with Breakthrough MEMS-Based Device
- 40 Optimal Wound Treatment Thanks to Modeling
- 42 Microscopic Magnetic Field Simulations with COMSOL Multiphysics

### PLASTICS

- 44 Modeling Helps Improve Safety in the Production of Teflon

### AEROSPACE

- 46 Reduced-Weight Reaction Sphere Makes Way for Extra Satellite Payload

### SENSORS

- 50 Optimization Slashes Energy Consumption in Silicon-Based MEMS CO<sub>2</sub> Detectors

### HYDROLOGY

- 54 Restoration of Lake Water Environments

### OFFSHORE

- 56 Making the Oil Supply Safer and More Stable

### IMAGING

- 58 Analysis and Simulation of Rock Properties

### SUPPORT

- 60 Tips and Tricks

### FOOD

- 62 COMSOL Assists Master Chef in Winning International Competition

### GUEST EDITORIAL

- 64 3D Direct Modeling: Removing Bottlenecks in Multiphysics Simulation

### CONTRIBUTORS

AltaSim Technologies	Harvard Medical School	Microsoft	SpaceClaim Corp.
CEA-MINATEC	HCL Technologies	Nofima	SYNGAS
Desktop Engineering	Massachusetts General Hospital	OCAS	Tech Briefs Media Group
ENEL	Massachusetts Institute of Technology	Riello Burners	Veryst Engineering
Ford Motor Company	MatWeb	Ritsumeikan University	VSG
German Federal Institute for Materials Research and Testing	Microvisk	SB Microsystems	Xi Engineering Consultants
		Scientific & Biomedical Microsystems LLC	



### ON THE COVER

The Ford Focus Electric, the company's first full production all-electric vehicle, will be available in late 2011.

PHOTO COURTESY OF FORD MOTOR COMPANY

## COMSOL NEWS

We welcome your comments on COMSOL NEWS; contact us at [info@comsol.com](mailto:info@comsol.com).

© 2011, all rights reserved. COMSOL NEWS is published by COMSOL, Inc. and its associated companies. COMSOL and COMSOL Multiphysics are registered trademarks of COMSOL AB. Other products or brand names are trademarks or registered trademarks of their respective holders.



# OPPORTUNITY



WE'LL HELP YOU DISCOVER  
A WHOLE NEW WORLD OF OPPORTUNITIES.

[ ]



AltaSim Technologies' team of engineers provide innovative and cost effective solutions for new product development, improved product performance, and innovative manufacturing technologies. Our unique S3 Process enables us to harness our engineering technology and advanced computational and multiphysics analysis capabilities. So you are able to explore, develop and apply alternative solutions - without the delays and expense associated with traditional testing and evaluation. Contact us today. We'll show you how a great opportunity can become a reality.

(614) 861-7015 | [www.altasimtechnologies.com](http://www.altasimtechnologies.com)

©2011 Altasim Technologies, Inc. All rights reserved.

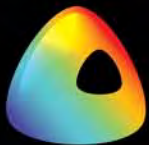

**ALTASIM**  
TECHNOLOGIES  
REALIZING TOMORROW'S TECHNOLOGY



# Multiphysics Analysis of a Burning Candle

These solution methodologies have been applied to a range of applications to predict the temperature distribution associated with a burning flame.

ALTASIM TECHNOLOGIES, COLUMBUS, OHIO

Over 150 years ago, Faraday provided the first comprehensive scientific study on the physics of burning candles. Complex combustion driven by the rate at which gases diffuse through each other produces a highly non-linear temperature profile through the flame. With local temperatures in the flame exceeding 1400 °C, heat transfer includes radiation, conduction, and convection components. The low melting point of the candle wax leads to a local phase change close to the wick that allows mass transport via capillary flow prior to combustion in the flame.

Any attempt to model candle operation accurately from the fundamental physics in its entirety would be an immense undertaking and require resources that are unrealistic. AltaSim Technologies combined COMSOL Multiphysics V 3.5 analysis software with generalized strategies to develop computational models of burning candles. These models focus on analyzing the heat transfer and fluid flow during steady state candle burning. Analysis

of the heat transfer combines conduction, convection, and radiation. Radiation from the candle flame was included in the models by defining a radiating surface of the flame that is non-locally coupled to the radiating gas volume. The radiation emanating from this surface is determined by the temperature distribution within the flame, and the gas within the flame is accordingly cooled due to the radiation. To reduce computational requirements, the complicated dynamic behavior of the plume was accounted for using artificial diffusion to generate a time-averaged approximation. Heat transfer within the liquid wax was modeled using an anisotropic thermal conductivity to account for convection in the horizontal direction.

Figure 1 shows the predictions of the velocity flow field using this approach for a half-burned, three-wick candle, clearly demonstrating spreading of the flow away from the flame. Predicted temperature distributions within the wax (Figure 2) and in the candle container compare favorably

with experimental measurements. These results can be used to predict the location of the solid/liquid interface during burning and temperature distributions in the candle and the surrounding environment.

These solution methodologies have been applied to a range of applications to predict the temperature distribution associated with a burning flame. The temperature and flow patterns are considerably influenced by the spatial location of the flame within a container, the container geometry, and the height of the candle within the container. Convective flow and heat transfer outside the immediate vicinity of the candle flame can predict the transfer of heat to nearby objects. ■

## ACKNOWLEDGEMENTS

This work was performed by L.T. Gritter, S.P. Yushanov, J.S. Crompton, and K.C. Koppenhoefer of AltaSim Technologies using COMSOL Multiphysics. For more information, visit <http://info.hotims.com/28057-152>.

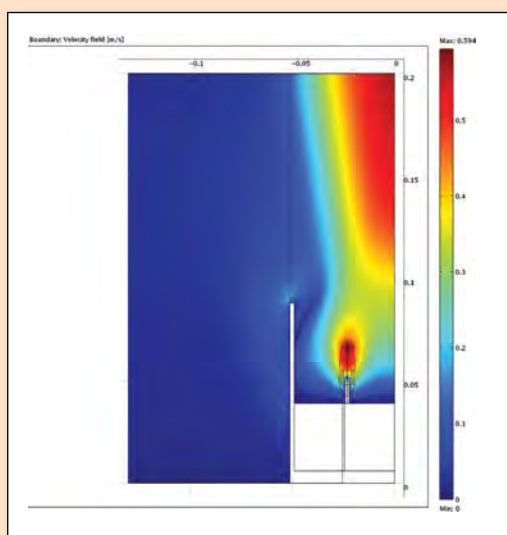

Figure 1. Velocity Flow Field for a burning candle at half-container height.

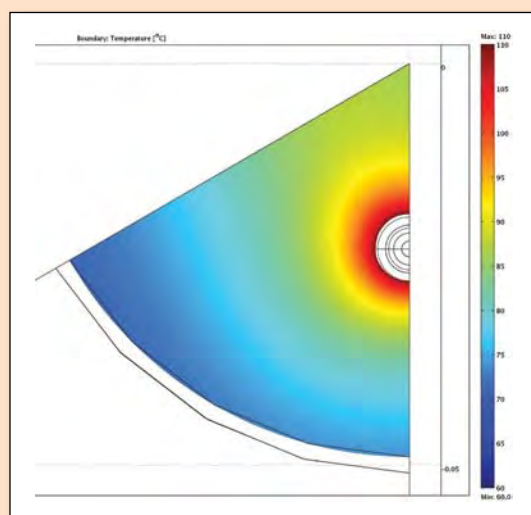

Figure 2. Surface Temperature of Wax during burning, 1/6th symmetric model.

# Capacitively Coupled Plasma Analysis

Multiphysics simulations can be used to assist with the development of new CCP processing technology.

ALTASIM TECHNOLOGIES, COLUMBUS, OHIO

Plasmas consist of electrons, ions, and neutral species interacting with each other and with externally imposed electromagnetic fields. Plasma etching and deposition of thin films are critical processes in the manufacture of advanced microelectronic devices. These processes commonly utilize a capacitively coupled plasma (CCP), in which the plasma is initiated and sustained by an oscillating electric field in a region between two or more electrodes. While CCPs are typically generated at frequencies in the 10-100 MHz range, some applications benefit from operation at lower frequencies. In this regime, free electrons are generated both by collisions between electrons and atoms or molecules, and by secondary electron emission caused by ion bombardment of the electrodes.

The multiphysics nature of plasmas presents enormous challenges for numerical simulations;

analysis of the CCP process presents added difficulty due to the existence of a plasma sheath, the dynamic behavior of the plasma, and the large number of RF cycles required to reach a periodic steady state. Power deposition into the plasma is highly non-linear and the strong gradient of the electric field in the plasma sheath may lead to numerical instabilities unless a sufficiently fine mesh is applied. Typical CCP reactors may also contain sharp geometric corners that can cause a substantial local electric field that provide unphysical ion fluxes.

AltaSim Technologies has performed one- and two-dimensional simulations of low-frequency RF discharges in axisymmetric CCP reactors for Maxwellian and non-Maxwellian cases using COMSOL Multiphysics. Electron transport properties and Townsend

coefficients were calculated using the two-term Boltzmann approximation as a preprocessing step to the numerical analysis of the plasma. Ion densities are shown in Figure 1 for a 1D simulation of a non-Maxwellian plasma. Extensions of the model to analyze the plasma behavior for a Maxwellian plasma in a 2D case are shown in Figures 2 and 3. The simulations incorporate the multiphysics nature of plasmas and consequently can be used to assist with the development of new CCP processing technology. ■

## ACKNOWLEDGEMENTS

This work was performed by L.T. Gritter, S.P. Yushanov, J.S. Crompton, and K.C. Koppenhoefer of AltaSim Technologies using COMSOL Multiphysics. For more information, visit <http://info.hotims.com/28057-153>.

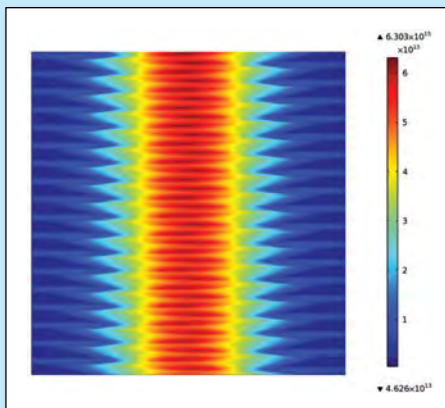

Figure 1. 1D Simulation of the CCP Process showing ion number density as a function of time.

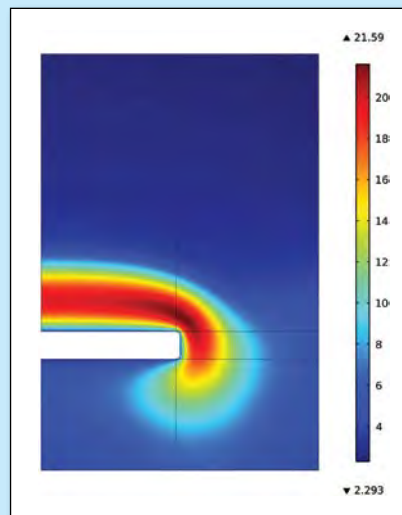

Figure 2. Electron Temperature in the sheath region from 2D simulation of the CCP process.

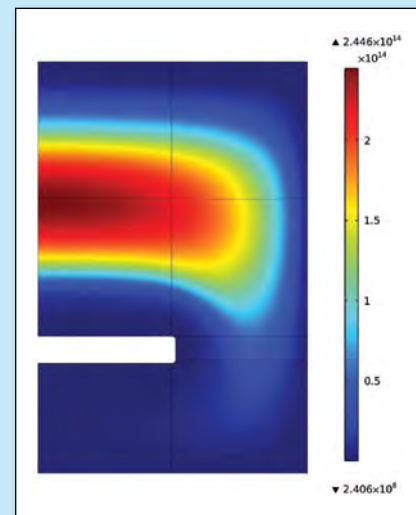

Figure 3. Electron Density in the plasma from 2D simulation of a CCP process.

# 3D Direct Modeling Streamlines Micro-Cogeneration System Design and Analysis Processes

Multiphysics software is used to analyze and optimize heat conduction and thermal structure interaction.

SPACECLAIM CORP., CONCORD, MASSACHUSETTS

**S**YNGAS specializes in thermal and micro-thermal technology, and designs and analyzes pre-production heating, cooling, and thermal insulation systems for a variety of applications. They provide engineering support to research centers and fuel cell manufacturers working with complex catalyst and hydrogen fuel cells for micro-generation systems.

Micro-cogeneration systems are refined to be as effective as possible at utilizing fuel cell power. These micro-cogeneration systems are built to provide efficient heating and cooling systems for home and commercial use by converting materials like kerosene or natural gas into hydrogen, which then powers the fuel cell and manages the energy flow for either heating or cooling. In homes, these systems are used for both heating and air conditioning applications. In commercial applications such as airplanes, there is never any shortage of heat due to the engines, and the systems are used to provide much needed air conditioning to keep passengers comfortable.

The company uses SpaceClaim and COMSOL software to analyze and optimize heat conduction and thermal

structure interaction. In order to design systems that get the most out of fuel cells, the company needs to constantly iterate the 3D geometry and test it in COMSOL to figure out what works and what doesn't. Previously, the company had to request edits from trained CAD experts or struggle with CAD on their own, which slowed implementation of ideas, consumed valuable time, and reduced the ability to serve new customers.

In search of a better solution, the company found SpaceClaim and saw that it was being utilized by numerous COMSOL users as a tool for analysis preparation and for 3D geometry editing and creation. SYNGAS uses SpaceClaim to analyze and edit more designs, enabling them to improve and increase the quality and the rate of output.

SpaceClaim imports geometry directly from SolidWorks and other CAD systems, significantly easing the process of making edits and updates to existing data. The company can easily de-feature CAD geometries — removing any parts, faces, or holes that are irrelevant to analysis — and then move to COMSOL to test the quality and efficiency of the model, and, if required, return the model to the native CAD system.

For concept modeling, SYNGAS is also developing new ideas in SpaceClaim. SYNGAS's complex models, many of which were originally created in SolidWorks, can be directly opened in SpaceClaim, which enables all the disparate parts to be merged into one solid to drive the analysis. In these assemblies, there are often numerous instances of small features such as screws in holes, which are problematic for COMSOL. Space-

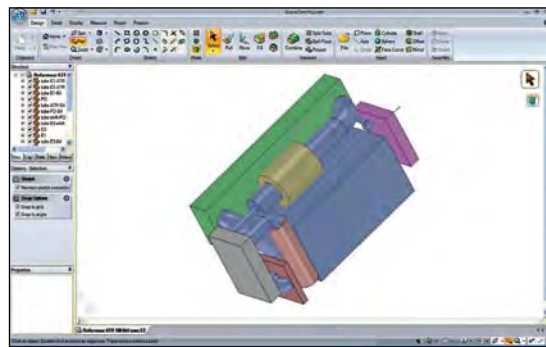

SpaceClaim Model of the Reactors and Heat Exchangers for a compact reforming system that produces hydrogen for a 100kW fuel cell stack.

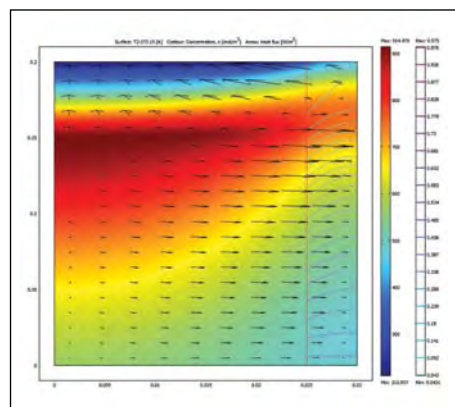

COMSOL Results of Heat Exchange and chemical reactions that occur while reforming hydrocarbons. This cross-section shows the temperature field and heat flux between two reactors.

Claim is used to first delete the screw design and then fill in the hole by extending surrounding material. Additionally, many SYNGAS models are drawn with fillets or round edges, which are often necessary to avoid stress concentrations at the straight intersections but are unnecessary for simulation. SpaceClaim allows modification of the drawing and the ability to change the angles to make sure everything is properly arranged for analysis.

SYNGAS focuses on conceptualization, not production, and a fully featured parametric CAD system was not the right tool to create and simulate concepts. Without intensive and time-consuming training, users became proficient with SpaceClaim's 3D Direct Modeling tools and were able to immediately concentrate their energy on their areas of expertise. The company's work is not to draw plans for machining, but to imagine and conceive new systems, which is done efficiently and effectively with SpaceClaim.

This work was done by Paul Gateau of SYNGAS using software from SpaceClaim and COMSOL. For more information, visit <http://info.hotims.com/28057-151>. ■



COMSOL Multiphysics®  
 + Windows HPC Server  
 = ACCELERATED SCIENCE



Windows® HPC Server 2008 R2

The complete, integrated platform for cluster-based, high performance computing. Combine the power of supercomputing with the ease of use of Windows.

Learn more at [www.microsoft.com/hpc/comsol](http://www.microsoft.com/hpc/comsol)

**Microsoft®**

The 2011 Ford Fusion Hybrid, with an estimated 41 mpg in the city.



## Lithium-Ion Battery Simulation for Greener Ford Vehicles

BY CATHLEEN LAMBERTSON, CONTRIBUTING EDITOR, TECH BRIEFS MEDIA GROUP

**W**hat does it mean to “go green”? For some it is as simple as putting out the recycling each week, while others choose bigger actions such as converting their entire homes to solar power. The debate over the benefits and drawbacks of environmental actions continues. For example, on one side, proponents of wind farms tout the benefits of alternative energy, while the other calls them eyesores. Consumers wonder if what they’re buying at the grocery store is really organic. When it comes to what’s truly environmentally sound, the answers aren’t always clear. But one area where progress has unquestionably resulted in a “greener” outcome is the advent of the hybrid electric vehicle (HEV).

HEVs combine the benefits of gasoline engines and electric motors, and can be configured to obtain different objectives, including improved fuel economy, increased power, or additional auxiliary power. Modern HEVs use efficiency-improving technology such as regenerative braking, which converts the vehicle’s

kinetic energy into battery-replenishing electric energy, rather than wasting it as conventional brakes do. According to the U.S. Department of Energy, benefits of HEVs include a reduction in CO<sub>2</sub>, reduced dependence on fossil fuels, and increased energy sustainability.

An increasing number of automakers are now offering HEV models, with leadership held by those who entered the market early. In 2004, the world was introduced to the Ford Escape Hybrid, the first American-built hybrid and the first hybrid SUV. The Environmental Protection Agency noted that the first-generation Escape Hybrid was 70% more efficient than the regular Escape with its full internal combustion engine. It won the North American Truck of the Year Award at the 2005 North American International Auto Show in Detroit, MI.

### A Hybrid History

After the introduction of the Escape Hybrid in 2004, Ford followed with the Mercury Mariner Hybrid in 2005 and the

Mazda Tribute Hybrid in 2007. In 2010, the company launched hybrid versions of the Ford Fusion and Mercury Milan. The non-electrified version of the Ford Fusion and the Fusion Hybrid, with an estimated 41 mpg in the city, won the 2010 MOTOR TREND Car of the Year®, along with a place on many “best green car” lists. The 2011 Lincoln MKZ Hybrid joined the North American lineup last fall and is the most fuel-efficient luxury car in America. All of the Ford hybrids are full hybrids, meaning they can run exclusively on battery power, exclusively on gas power, or on a combination of both. In total, Ford has sold 170,000 hybrids to date.

“With HEVs, it’s all about delivering and receiving energy on short time scales — high power capability — that is, breaking and accelerating. The real reason hybrids give you over 40 miles per gallon is because you’re driving around with a smaller combustion engine that is assisted by the battery on acceleration with energy from the last braking,” stated Dawn Bernardi, Ph.D., a battery





“Since automakers already believe they have tapped most of the potential of NiMH technology in HEVs, they are now moving toward the use of lithium-ion (Li-ion) technology due to its higher energy density, higher power density, and potential cost savings.”

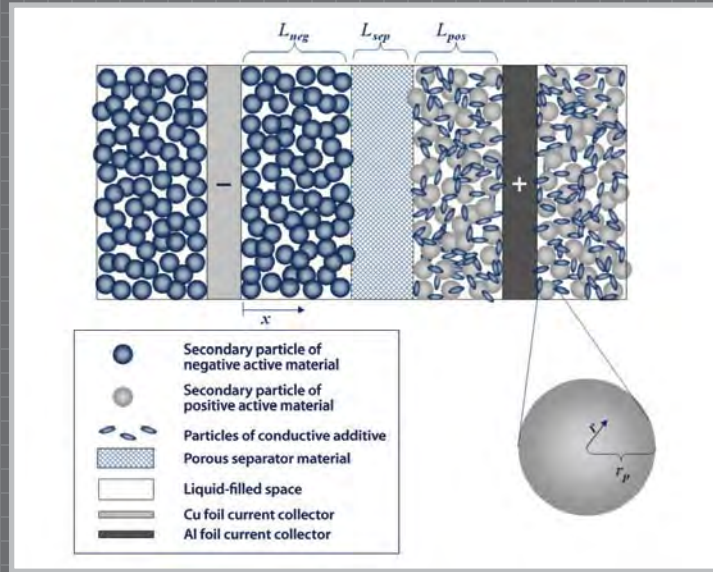

Figure 1. Diagram showing the basic components of a battery. The (+) and (-) refer to the positive and negative terminals, respectively. The simulation equations are solved in the two dimensions ( $x$  and  $r$ ) throughout the negative electrode, separator, and positive electrode domains, denoted by  $L_{neg}$ ,  $L_{sep}$ , and  $L_{pos}$ , respectively.

research engineer at Ford Motor Company in Dearborn, MI. “You experience the same performance as you would with the larger engine of a non-electrified vehicle.”

Ford’s next-generation HEVs, plug-in hybrid electric vehicles (PHEVs), and battery electric vehicles (BEVs), like the Focus Electric, will build on the company’s success and expertise with its Fusion Hybrid and Escape Hybrid vehicles.

### The Role of the Battery

Battery technology has a critical role in the development of the next generation of electrified vehicles. Today’s batteries are a far cry from the lead-acid batteries used for a century in the automobile. The 12-volt lead-acid battery used in traditional automotive applications is rapidly giving way to sophisticated, higher-energy, and higher-power batteries as the industry shifts further toward electrification.

Currently, nickel metal hydride (NiMH) batteries are the energy-storage technology of choice for most HEVs in the auto-

Figure 2. Experimental and model simulation results for a 40-second discharge pulse followed by a 300-second rest period for three different current pulse magnitudes. Experimental results are the wider circles and model simulations are the smaller dots. These pulses relate to how a battery would respond in an HEV to bursts of acceleration at three different levels of intensity: 3C, 5C, and 10C, corresponding to weak, medium, and strong acceleration. Finding ways of maintaining voltage during these pulses would result in increased fuel economy. Minimizing the concentration variations shown in Figure 3 would help to maintain voltage during current pulses. Simulation results were obtained using COMSOL 3.5a.

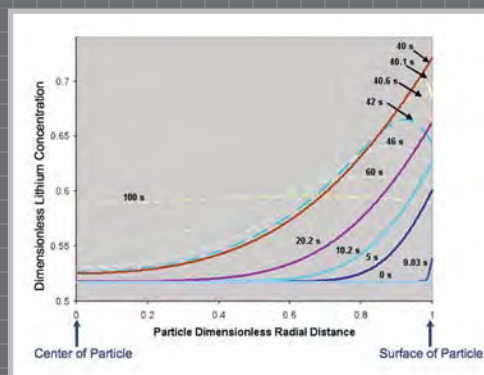
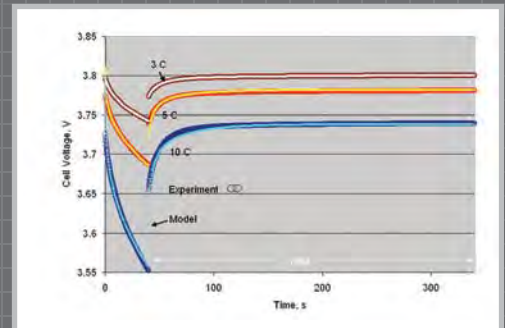

Figure 3. Simulations of lithium concentration throughout a particle (located at the aluminum current-collector interface) within the positive electrode during a 10C discharge pulse. The concentration variations shown contribute to a loss of voltage during the pulse and are dominantly accountable for voltage relaxation during the rest period. Simulation results were obtained using COMSOL 3.5a.

D.M. Bernardi and J.-Y. Go, Journal of Power Sources, 196 (2011) 412–427



motive industry. The nickel used in these batteries is lighter than lead, helping the battery deliver twice the power output for the weight as lead-acid batteries. All of Ford's HEVs on the road today use NiMH batteries.

"Technological advances in NiMH batteries at the cell level are responsible for much of the evolution of the pack design from the Ford Escape to the Ford Fusion. But these advances constituted the last of the 'low-hanging fruit' for NiMH," explained Dr. Bernardi. Since automakers already believe they have tapped most of the potential of NiMH technology in HEVs, they are now moving toward the use of lithium-ion (Li-ion) technology due to its higher energy density, higher power density, and potential cost savings.



Dawn Bernardi, Ph.D., is a battery research engineer with Ford Motor Company in Dearborn, MI.

### The Lithium-Ion Advantage

Li-ion batteries are commonplace in the world of consumer electronics. They're lighter and more energy dense than other types of batteries, making them ideal for laptop computers, mobile phones, and other portable devices. For use in HEVs, Li-ion battery packs offer a number of advantages over the

NiMH batteries that power today's hybrid vehicles. In general, they are 25-30% smaller and 50% lighter, making them easier to package in a vehicle, and can be tuned to increase power to boost acceleration or to increase energy to extend all-electric driving distance. "The hybrid-electric vehicle is the next frontier for the lithium-ion battery. To the

user, all these advantages could translate to better fuel economy at lower vehicle cost," said Dr. Bernardi.

Intensive development work is now underway to prove-out Li-ion technology for the auto industry, and Ford is using its extensive experience in BEVs, PHEVs, and HEVs to test the technology rigorously for its critical role in high-volume electrified vehicles of the future.

"At Ford, we believe lithium-ion batteries have incredible potential for the next generation of electrified vehicles, and we're already using lithium-ion technology in test units for the battery-electric vehicles that are part of our new electrification strategy," said Ted Miller, senior manager of energy storage strategy and research at Ford Motor Company. "There are still technical challenges to make lithium-ion technology work in high-volume automotive applications and we are working hard to address those."

### Modeling and Simulation

To design affordable, fuel-efficient HEVs, manufacturers require a complete understanding of battery life and performance characteristics. For example, an automobile is expected to have a 10- to 15-year lifespan, so researchers at Ford need to ensure that new battery designs are going to last that long as well. For work in this arena, modeling and simulation is invaluable.

"In order to know that the battery is going to last the life of the vehicle, we'd have to do at least 10-years worth of testing. But under our accelerated product development, we don't have 10 years to put out a vehicle; we have maybe 3 to 4 years," explained Dr. Bernardi. "In a sense, modeling and simulation allow us to go into a time machine — fast-forwarding into the future — to help us determine how a battery will perform after 150,000 miles based on data that we have right now. It helps us make better decisions with less test time."

Batteries themselves are complex devices, with behavior that is governed by a multitude of interdependent physical effects and chemical processes (see sidebar on page 11). Batteries for automotive propulsion are even more complicated be-

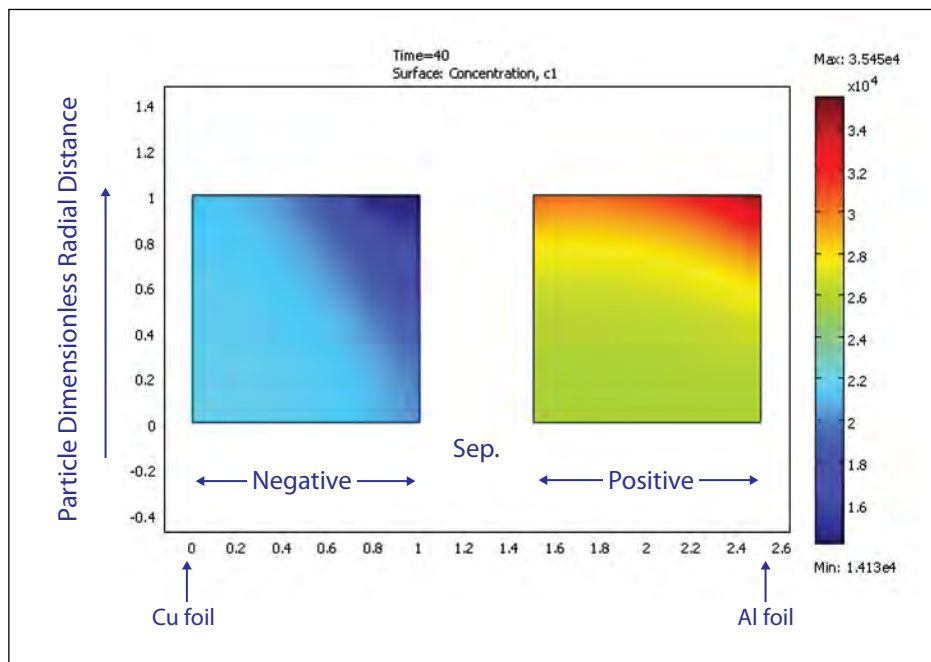

Figure 4. Simulations of lithium concentration throughout all particle locations within the positive electrode during after 40 seconds of a 10C discharge pulse [see Figure 2]. Regions denoted "Positive," "Sep.," and "Negative" correspond  $L_{neg}$ ,  $L_{sepr}$ , and  $L_{pos}$ , respectively in Figure 1. The color scale from deep red to deep blue is associated with highest and lowest lithium concentration. Simulation results were obtained using COMSOL 3.5a.



cause they must be designed to function properly in a large range of temperatures and over hundreds of thousands of miles.

According to Dr. Bernardi, the search for optimal electric-drive architecture requires simulation software that affords a degree of flexibility to the researcher. “In research, one needs to examine the effect on behavior of a newly developed electrode material, a given parasitic lithium consumption reaction, or even a more accurate description of solid-state lithium transport. All of these are examples of research efforts underway at Ford, where researchers use software to look into new electrode materials and new degradation and life-limiting mechanisms.”

Simulation helps provide a more fundamental understanding of the battery system, not only for the researchers and the engineers using it, but to others as

well. “If I’m giving a presentation and show an animation of concentration profiles throughout particles and how they change during discharge, then I can explain why the voltage is reduced when you punch the accelerator (see Figures 3 and 4). What’s happening is that you’re running low on lithium somewhere, and the simulation results will show you exactly where,” stated Dr. Bernardi. “This more fundamental understanding of battery behavior will help Ford to increase its understanding of overall system behavior. It could support better designs and faster-to-market green vehicles.”

### The Future

Going forward, electric-drive vehicles (BEVs and PHEVs) will be some of the advanced technologies offered by the automotive industry. For BEVs, however,

some believe the range of the vehicles will need to significantly improve before the vehicles gain widespread adoption. That increased range may be accomplished in part by investigating new battery materials.

“My perspective is that we will need to find a way to increase vehicle all-electric range without sacrificing functionality. We’ll be ‘eeking out’ as much range from lithium as possible through improved materials and designs. This will require a concerted design and development effort with hardware builds and software simulations,” said Dr. Bernardi. “New materials mean new chemistry; new chemistry means we need flexibility. In research, our designs are not fixed; we’re always looking for something better. If we fix our designs, then it’s not research anymore.” ■

## The Different Physical Processes in a Battery

BY ED FONTES, COMSOL

Depending on what part of the battery you want to investigate, design or optimize, a number of different physical processes would need to be considered, and modeled together.

As a battery’s prime purpose is to produce usable electrical energy, it’s most likely that your model will have to consider the conservation of electrical charge. This involves electrons flowing through current collectors and electrode matrices, and electric charge transported as ions through electrolytic solution, separators and/or membranes. A transfer of electrons is required at the interface between these two transport mechanisms to ensure the electric circuit is complete. This happens through electrochemical reactions occurring at the electrodes, which are dependent on the electric potential and concentrations of the reactants and products at the electrode surfaces, along with other electrochemical kinetic parameters.

These electrochemical reactions are also integral to the description of your battery’s material balances, and the amount of chemical substance that is available to provide your electrical energy. Material balances also need to consider the transport of chemical species through diffusion, migration and convection to and from the electrode surfaces, as well as any possible chemical reactions that occur in the electrolytic solution.

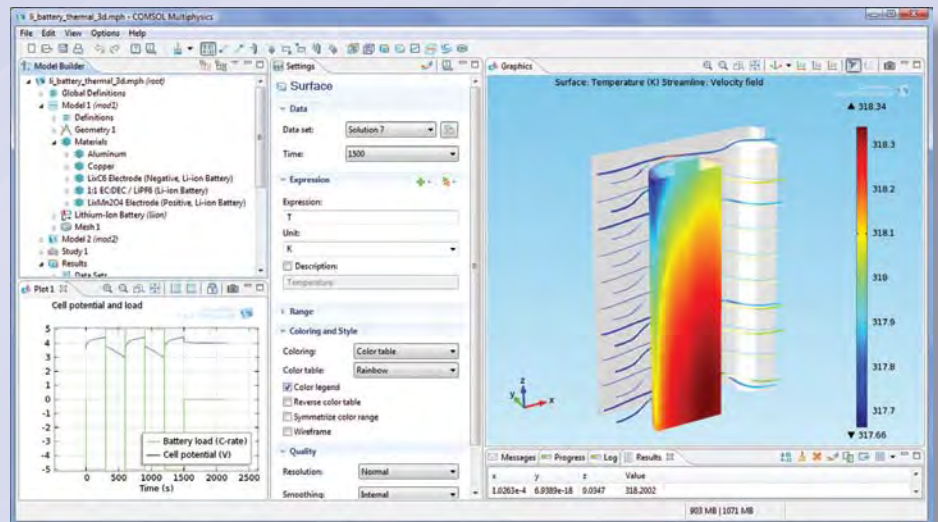

A major design component in a battery is how it reacts to heat. This can be imposed upon it from the battery’s operating environment, such as if it sits close to the motor in a hybrid car, as well as created through joule heating in the circuitry and heats of reaction. These all need to be accounted for as energy balances and help in determining operational parameters such as the flow rate of cooling air along with thermal stresses.



# Wind Turbine Noise Reduction

Modeling of a megawatt wind turbine system enabled Xi Engineering Consultants to address a problematic tonal resonance with an innovative solution that minimized the cost of remedial work for their client.

BY JENNIFER HAND

**N**oise from wind farms falls into two categories: aerodynamic noise is created by the blades of a turbine swishing through the air while mechanical noise is associated with the machinery housed in the nacelle of a turbine. As mechanical noise tends to be tonal, it is this that is most often a nuisance factor for residents living nearby. As a result there are strict regulatory standards throughout Europe and North America and when operators do not meet these requirements they face potentially heavy penalties.

“Within this complex model we could see that there were certain hotspots near the top of the tower where the tower skin was rippling.”

“People perceive noise, but often what they are really noticing is vibration,” comments Dr. Brett Marmo, Senior Consultant at Xi Engineering Consultants Ltd, an Edinburgh-based company that specializes in complex vibration issues. One of Xi’s recent projects was carried out for the manufacturer of a set of megawatt scale wind turbines emitting excessive noise in the 800-830 Hz frequency band.

The manufacturer had already identified that the most likely source of noise was the meshing of teeth within the gearbox and in a major project had lifted the 15-ton gearbox out of one of the 80 m high towers and replaced the rubber buffers beneath it. This had only exacerbated the problem. It was not at all clear how the continuing noise could



Wind Farm in the Scottish Southern Uplands.

be addressed without considerable redesign and remedial work, which would be both expensive and disruptive, given the significant number of turbines involved. As Dr. Brett Marmo explains, “We were brought in to address this vibration by tracking it to the source.”

## Seeking the Source

After a thorough study of existing design data and an extensive site survey in which sensors were attached to the turbine towers, Xi Engineering confirmed

that the source of the noise was indeed the gearbox. “We were able to ascertain that at normal running speed the teeth on a set of gears make contact around 820 times per second. In other words, we had the sound of 820 clashes each second,” notes Dr. Marmo. “However it was not that simple. The original noise was being amplified somehow and we suspected the involvement of the tower’s steel skin. Every structure has a harmonic and in this case the tubular steel tower had a series of resonances between 800-900Hz.”



Xi has extensive experience with simulation and used COMSOL Multiphysics to develop a model of the tower, the rotor blades and the nacelle housing the gearbox (Figure 1). The model incorporated all of the air inside and outside the turbine so that engineers could identify the modal shape of each vibrating element and see exactly how vibration was travelling out of the gearbox. This led them to the tower wall where resonances around 820Hz were clearly visible. The next step was to make an eigenfrequency model of the tower structure and skin. Dr. Marmo again: “Within this complex model we could see that there were certain hotspots near the top of the tower where the tower skin was rippling at resonant frequencies of 800 and 830 Hz. These resonances were amplifying the gearbox vibration and producing the annoying tonal noise.”

### Keeping it Simple

“Our philosophy is to begin with simple solutions such as buffers and springs that isolate the source of the vibration,” comments Xi Operations Manager, Barry Carruthers. “Where we can, we will develop passive correction rather than an active intervention that may require tuning and maintenance. In this case the design solution was to break the vibration pathway between the gearbox and the tower wall and the simplest method would have been to modify the rubber buffers below the gearbox. However engineering constraints meant that it was impractical either to stiffen or soften these. The most effective alternative solution was to coat the inside of the tower with a specialist material that reduces the amplitude of the vibration.”

There were two major considerations: the material was expensive and with each tower measuring 2.5m across the top and 4m at the bottom the potential surface area to be covered was extensive. In addition, installation would be costly. The material could only be fitted by Rope Access engineers working inside the tower, but between integral platforms. The big question was exactly how much material would be required to solve the noise problem? The only option was to create a third model in COMSOL Multiphysics to

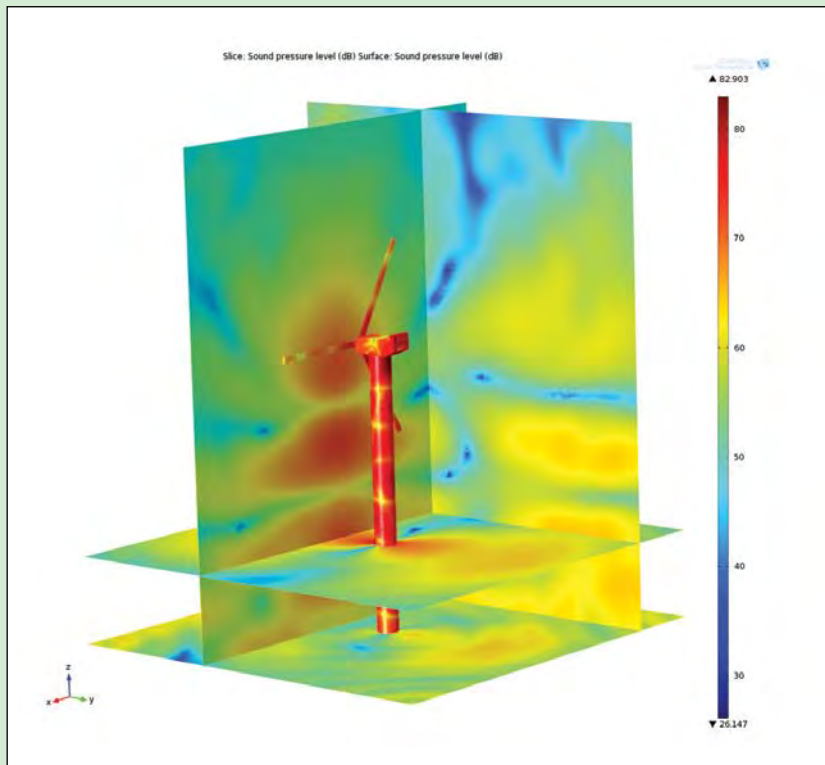

Figure 1. Acoustic-structural interaction model of a wind turbine surrounded by air showing the vibration acceleration amplitude of the turbine and slices through the air showing the resultant sound pressure level. The figure here shows vibration with localized amplification of the noise at the top of the tower (red area).

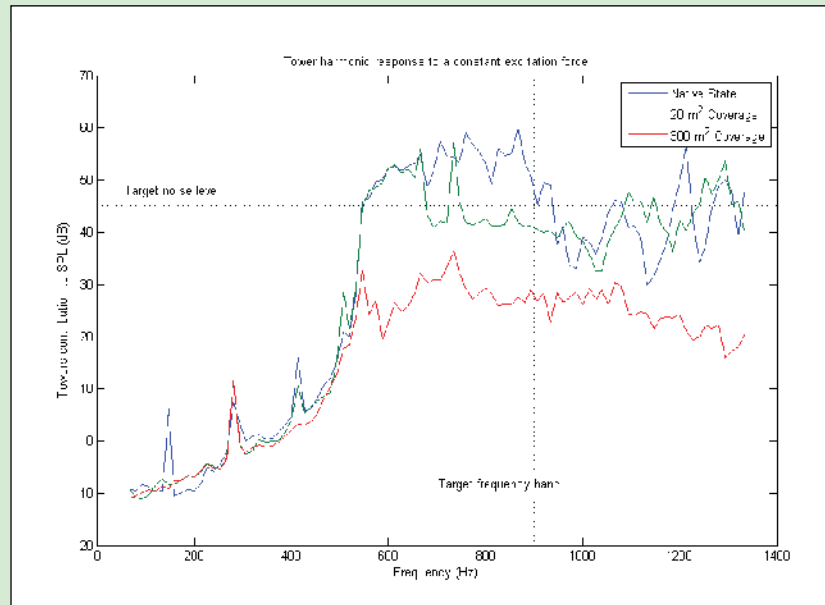

Figure 2. The sound pressure level measured at a virtual microphone outside that tower for: the wind turbine in its native state; when the top 20 m<sup>2</sup> of the inside wall is covered with the anti-vibration material; and when the top half of the tower (300 m<sup>2</sup>) is covered in the anti-vibration material.



**“We were able to conduct virtual testing and explore our options without the real-life costs associated with an iterative process.”**

simulate the effects of the material inside the tower (Figure 2).

“We made an acoustic structural interaction model of the tower walls and the internal and external air. We determined what the sound level was 50m from the tower when different surfaces of the tower were covered in the material, rather like using a virtual microphone. We began with the hotspots identified close to the top of the tower in the eigenfrequency model and experimented with different amounts of material. As we adjusted the amount of material in the wall we reached a point where the noise dropped to a satisfactory level. We continued to adjust the coverage until we had also minimized the amount of material required.”

The high costs of the material would have meant that full coverage of the 600 m<sup>2</sup> surface inside the tower would have cost tens of thousands of pounds.

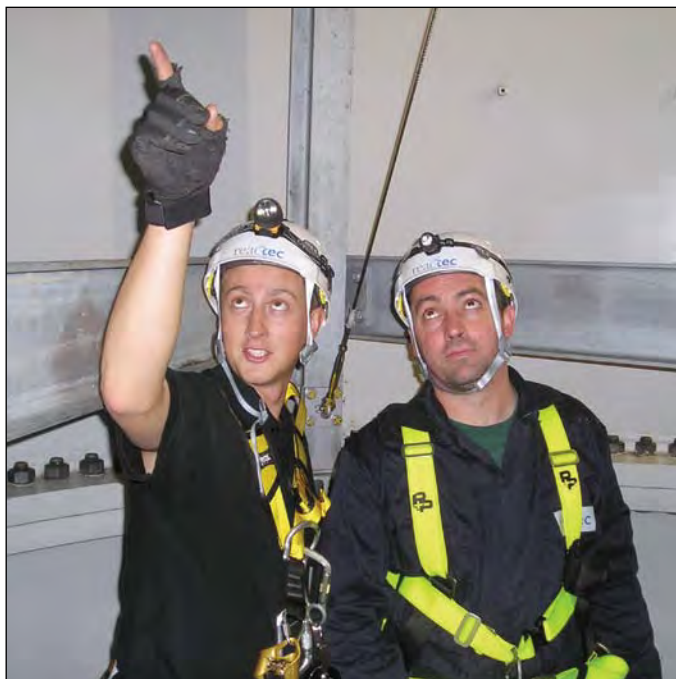

Barry (left) and Brett (right) in a turbine tower during the southern upland project.

Even if material had only been applied to the top part of each tower, 100 m<sup>2</sup> per unit would have been needed. Given the number of turbines, the bill would have been substantial,” reports Mr. Carruthers. “Instead, we were able to advise the client that only 20 m<sup>2</sup> of material was required for each tower. One prototype installation confirmed our findings exactly: the noise was sufficiently attenuated and our client was extremely happy.”

### The Value of a Virtual Test Bed

According to Dr. Marmo, it is difficult to overestimate the value of being able to simulate in such situations. “From our initial survey we knew that the tower was resonating and without the facility to model within COMSOL Multiphysics we would have had to go back and cover the whole of a 80 m high tower with sensors. Instead, we were able to skip that phase altogether with our first analysis model.” Mr. Carruthers continues, “We were able to conduct virtual testing and explore our options without the real-life costs associated with an iterative process. Trial and error on-site, with expensive materials and labor,

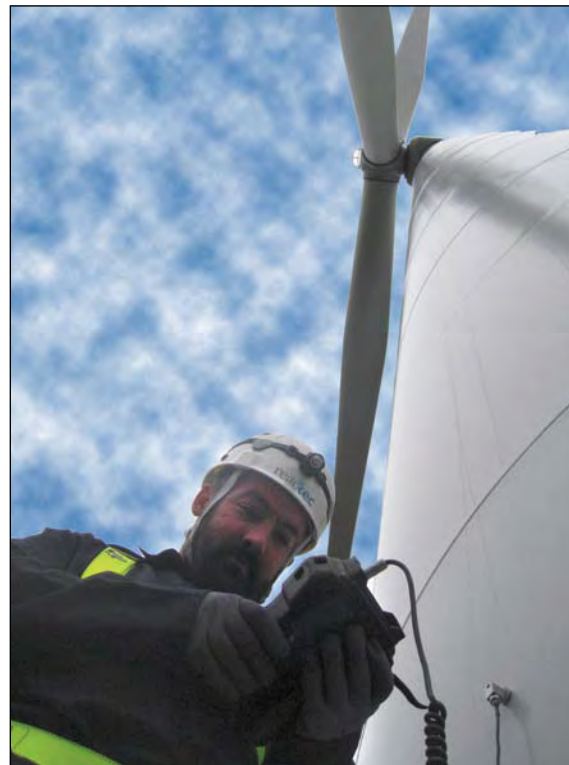

Brett monitoring vibration of a wind turbine tower with a hand held accelerometer.

is more than 30 times the cost of additional simulation and analysis — the key is to investigate virtually, but solve in reality only once.”

Xi has been using COMSOL Multiphysics since 2006 when it was commissioned to solve a complicated seismic vibration issue in the Southern Uplands of Scotland. “It is unusual to be able to conduct different types of analysis within one single engineering application. As vibration experts we are particularly interested in how structures interact with acoustic waves or fluid flow and COMSOL Multiphysics allows us to plot dynamic relationships; get an overview of what is going on; play around and do complex multifaceted things more easily. Vibration issues within systems can be very complex and while many companies can identify a problem, they cannot solve it. Our value comes from providing a solution and COMSOL Multiphysics assists us in what can be an extensive and difficult process.” ■

### LEARN MORE

[www.comsol.com/papers/8720/](http://www.comsol.com/papers/8720/)

**solid mechanics / fluid flow**  
**material kinetics / nonlinear materials**  
**polymer modeling / acoustics**  
**mass transfer / heat transfer**

**veryst engineering**

consulting for a multiphysics world



Experienced COMSOL Multiphysics Consulting team using engineering fundamentals and modeling to solve complex industrial problems:  
Biomedical / Consumer Products / Energy / Manufacturing / Transportation

Veryst Engineering, LLC / [contact@veryst.com](mailto:contact@veryst.com) / 781-433-0433



# The Burning Need for Modeling

BY GIANLUCA ARGENTINI, RIELLO BURNERS, LEGNAGO, ITALY

When we think about heating and cooling, we often neglect to consider the energy consumed by components we take for granted such as fans, whether for distributing air into a room or for feeding it into a burner for combustion. The energy consumed by fans depends on many aspects, but in a high-power burner (> 1 MW) the percentage of energy consumed by fans is about 30 – 40% of the total needed to run the system, which can range from 150W for a small ventilator to 25 kW for a large burner. In fact, in residential and domestic burners (up to 100 kW thermal power), due to small geometries, the percentage can be much higher, with up to 80% of the electrical energy for the system consumed by fan.

In addition, new ecology regulations in EU Directive 125/2009 addressing fans for industrial purposes fixes limits of about 40 – 50% for fan power consumption, putting additional pressure on manufacturers to improve their products. There is, in fact, great potential for saving energy as well as manufacturing costs in a well-designed fan, and here modeling plays a very important role because it not only saves considerable engineering time but also results in optimal designs. By reducing power consumption, it is possible to use a smaller motor to obtain the same performance. Other benefits include reducing the overall weight of burners and improved design of the components in the combustion head.

This type of continual development is part of our job at Riello Burners. We are an internationally active company in the fields of oil and gas combustion, ventilation systems and hydraulic pumping. Our headquarters and main production facility is in Legnago near Verona, Italy, and we employ roughly 600 people. In terms of burners, we manufacture high-efficiency low maintenance burners with capacities from 10 kW to 32 MW, and they are used in the full range of residential and commercial heating applications as well as in industrial processes.

## Two Key Components

The ventilating structure is fundamental to a burner because it ensures a continuous and appropriate flow of air into the combustion head where the flame is located. There are two principle ventilation components: the rotating wheel or impeller, and the external chassis in which it operates, and this is also called a volute. The basic challenge when designing a fan is to determine the configuration of the impeller and volute so as to obtain high values of static pressure and

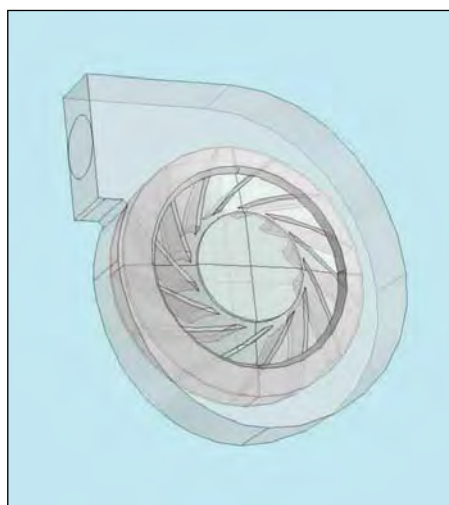

Fig 1. Geometry of a burner ventilation fan consisting of the rotating impeller in the center and an expanding volute.

flow rate at the volute's outlet while also maintaining high mechanical efficiency, which means less electricity required to run the fan.

The particular fan we recently studied is a relatively complex system and consists of an impeller with 13 backward-curved blades and a volute with a linearly expanding external radius (Fig 1).

Prior to using COMSOL Multiphysics, we developed our fans and created their characteristic curves using only experimental tests with Pitot tubes; these are tubes with only one open end which is pointed directly into the fluid flow, and the static pressure measured inside the tube corresponds to the flow using Ber-

noulli's equation. The problem with this type of testing is that if you change the geometry or some physical boundary condition you must run new tests, each requiring almost an entire day.

In an effort to make a better choice between the geometries and to reduce design time, we turned to mathematical modeling. Using the “frozen rotor” method, the construction of a model and running of the computations usually takes only two hours. I now have a rapid way to test new concepts or designs that I first work out using theoretical methods based on fluid dynamics and mathematical resolution of some partial differential equations. The numerical simulations then point me in the direction of the configuration that's probably the best one from the outset.

Before simulating, we would create and test tens of physical prototypes during the course of a year. Most of the time, these models would exhibit some problem. With COMSOL, I've used two possible geometric configurations of the volute which we created and tested. The final configuration has exhibited no problems and has very good performance. The time between starting the models and the ending of experimental tests was about one month compared to a year.

## A Fixed and Moving Geometry in One Model

Simulating the flow in the total air domain in the overall structure is typically a difficult task using computational fluid dynamics due to the interaction of a moving geometry (the impeller) and a fixed geometry (the volute). To attack this problem, we use the frozen rotor method, which is a numerical technique for approximating the flow velocity field at the geometric interface between a rotating air domain in the impeller and the static air domain in the volute. Using COMSOL's CFD Module, we computed a velocity  $v_1$  in the entire geometry assuming a flow entering axially from the center disk of the fan and leaving the housing from



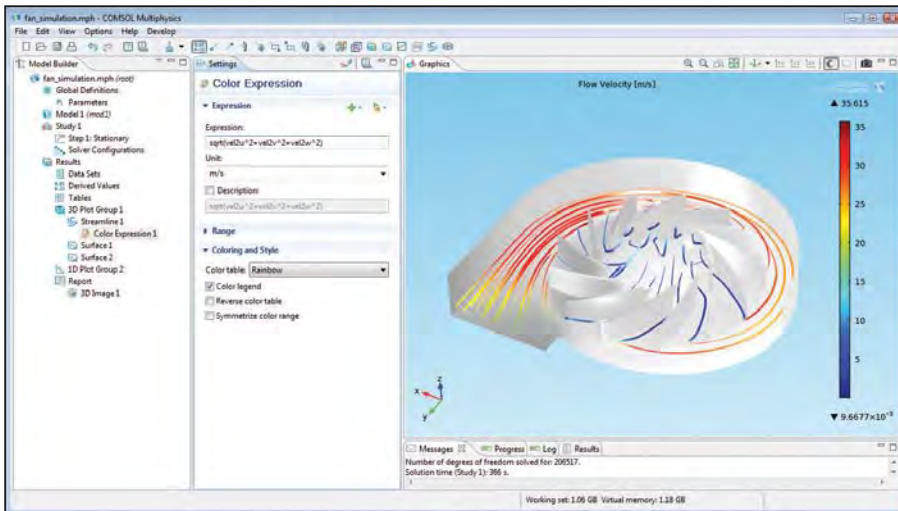

Fig. 2. Streamlines showing the velocity into the impeller and the velocity into the housing

the outer section without considering any rotation. The result is the “frozen” velocity field into the impeller, and more importantly, the value of  $v_1$  is used in the frozen rotor equations for the boundary data for  $v_2$ . Then a second computation determines this field only in the domain of the volute (Fig. 2).

With experiments we determined that the fan pressure computed by the simulation has a profile that is in very good agreement with experiments. These good results proved to us that the frozen rotor method can be a valid algorithm for simulating the rotating fluid domains in the static casings.

I found the software particularly efficient in creating the geometry and the mathematical treatment of the boundary conditions where I can express them using analytical formulas. For example, in the frozen rotor method, the correct formulation of the velocity field on the interface between the rotating and static domain is very difficult to obtain without the ability to declare the algebraic conditions of compatibility.

I have noticed that a significant advantage of using COMSOL for our ventilation structures is a more optimized shape of the volute, which results in a more laminar and therefore more efficient air flow towards the burner’s combustion head. This improved flow means that we can use less electric power and yet achieve the same flow rate. For the

end user (e.g. a family or a company), the direct advantage can be a less expensive burner; the more-important indirect advantage is the total energy saving for the environment. For example, if for a

ventilator we could reduce the power consumption from 250W to 200W with the same flow rate, the energy savings in the case of 10,000 parts/year – typical annual sales volume for a fan of the type being modeled – is 0.5 MW that need not burden the environment.

Future plans for COMSOL are to develop a model that starts with the frozen rotor method and couples flow and materials structures because one of the more important challenges in the field of fans is to minimize vibrations, energy losses and noise. ■

### ACKNOWLEDGEMENTS

The author would like to thank his colleagues at the Angiari Combustion Research Center for their help and suggestions during executions of ventilation experiments.

### LEARN MORE

[www.comsol.com/papers/7988/](http://www.comsol.com/papers/7988/)



### About the Author

Gianluca Argentini is a manager in the R&D department at Riello Burners working on ventilating structures and the fluid dynamics of rotating components. He has a Laurea in Mathematics from the University of Padua and a Masters in Scientific Computing and Fluid Dynamics from the University of Erlangen (Germany). He first worked as a mathematics instructor at the university level and then joined Riello Burners to perform scientific computations and develop mathematical models.

# Sea Floor Energy Harvesting

BY NAGI ELABBASI, BRENTAN ALEXANDER, AND STUART BROWN, VERYST ENGINEERING, NEEDHAM, MASSACHUSETTS

**E**nergy harvesting, converting surrounding motion into electrical power, is growing into an increasing number of applications. We're aware of photovoltaics, hydroelectric stations, and wind turbines as large scale energy harvesting technologies. Smaller scale technologies are in development as well to produce smaller amounts of local power. Uses of energy harvesting include using vibrations to power distributed sensor nodes, using wave energy to power buoys, and using low speed ocean currents to recharge submerged sensors for tsunami detection.

All of the energy harvesting technologies are fundamentally multiphysics design problems. Motion from some source is coupled to a mechanical system that in turn is coupled to an energy conversion system to produce electrical power. Motion can be vibration, direct mechanical contact, or fluid flow. Energy conversion can be electromagnetic, piezoelectric, electrostatic, or electrorestrictive. Given this diversity, COMSOL provides an important simulation tool that can account for all the coupled physical processes for initial proof of concept evaluation, and later for product design and optimization.

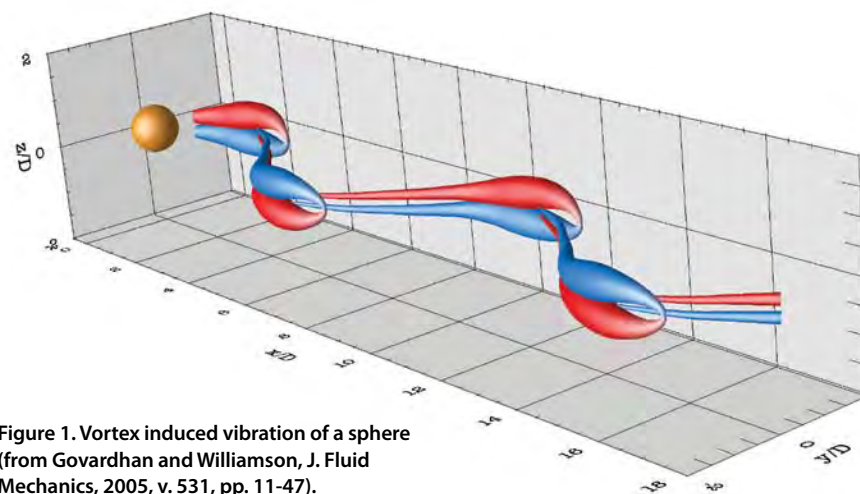

Figure 1. Vortex induced vibration of a sphere (from Govardhan and Williamson, *J. Fluid Mechanics*, 2005, v. 531, pp. 11-47).

## Energy from Ocean Currents

Veryst Engineering has been working for several years in energy harvesting, providing design solutions for a variety of industries. One example is harvesting energy from constant, low speed ocean floor currents to power ocean floor sensors. Such sensors are used in naval applications, environmental monitoring, earthquake monitoring and oil exploration. Ocean floor sensors are currently battery-powered, requiring

very expensive battery replacement or recharging using ship based services. Although the cost of the batteries may be low, the cost of sending a ship out to replacement can be prohibitively high. By some estimates, the in-field maintenance of underwater sensors arrays in naval applications can cost hundreds of thousands per service interval.

To address this problem, Veryst has been working to develop a technology to harvest energy from low speed sea floor ocean currents. The concept illustrated in Figure 1 converts a steady fluid flow into an alternating train of vortices that can be directed to an energy conversion device. A bluff body is placed on the ocean floor into the steady low speed current. The geometry of the bluff body is selected to cause the flow to develop a laminar Karman vortex street. A vane is inserted downstream from the bluff body and pivoted at its leading edge. The vortices introduce an alternating motion in the vane which can then be coupled to an electromagnetic generator to produce power. The design is simple, uses basic off-the-shelf components, and can be encapsulated to eliminate the need for moving shafts and reduce biofouling. An alternative Veryst design involved harvesting energy from the oscillating force on the bluff body, without the vane.



Xiaohu Liu, Stuart Brown, and Nagi Elabbasi, of Veryst Engineering.

“COMSOL provides an important simulation tool that can account for all the coupled physical processes for initial proof of concept evaluation, and later for product design and optimization.”

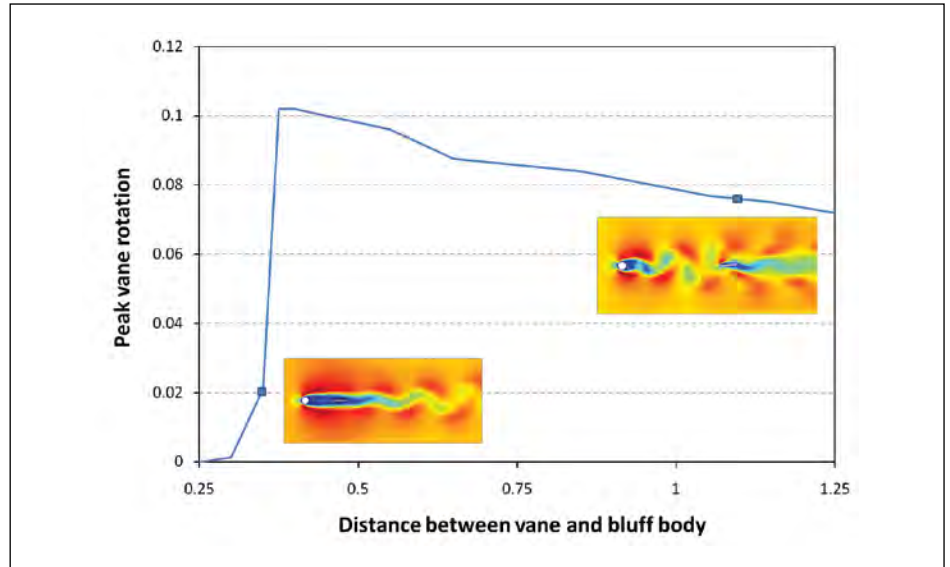

Figure 3. Effect of distance between vane and bluff body on vane rotation.

### A Reliable Model

Veryst modeled the flow and mechanical motion of the vane in COMSOL to examine the interaction between fluid velocity, bluff body geometry, vane geometry, and vane position. This energy harvesting application is challenging due to the small amounts of energy involved. A few watts can make a big difference in the feasibility of the energy harvesting design. Empirical equations are not suitable for validating the design since they do not provide the desired accuracy, and prototyping and experimentation can-

not realistically be done for all possible design parameters. A reliable multiphysics modeling tool is required. COMSOL's main appeal was the seamless integration of different physics modules. COMSOL provides additional physics models if we need to account for other processes such as electromagnetic fields, or more advanced solid mechanics effects.

It was more efficient to model the vane as a rigid body with a single rotational degree of freedom about its leading edge instead of a general fluid-structure interaction (FSI) analysis. The kinematic

and dynamic relationships governing the rotation of the vane were input to COMSOL directly in equation form. This direct input of equations is a unique COMSOL feature that simplified the modeling. A moving mesh feature is used to update the CFD mesh due to the deformation of the vane. Simulations were performed without the vane to validate the CFD model. The resulting laminar vortex shedding flow was in agreement with Karman vortex street predictions in terms of both frequency and amplitude of oscillations.

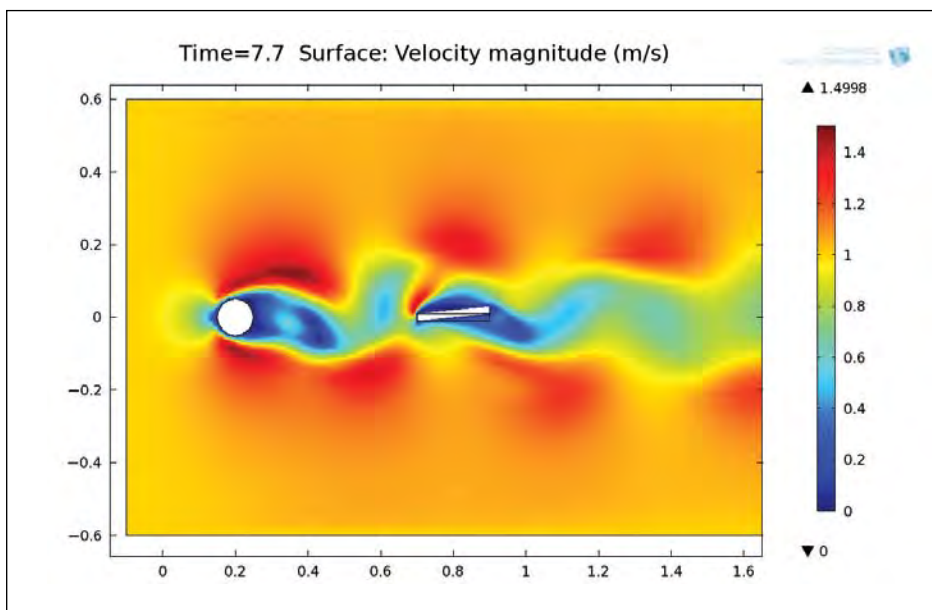

Figure 2. Velocity contours for a specific energy harvester configuration.

### Design Optimization

The multiphysics COMSOL simulations provided immediate prediction of the amount of available energy for conversion and facilitated the design optimization of this energy harvesting device. Figure 2 shows one configuration where there is vortex shedding. Figure 3 shows the effect of one parameter, the distance between the bluff body and the vane, on the amount of vane rotation, which determines the amount of available energy. This type of parametric sweeps is easy to perform in COMSOL. There is an optimal range of locations for the vane. When placed in closer proximity to the bluff body the vane delays the formation of the vortices and when placed further away the effect of vortex shedding gradually diminishes. ■



## Around the Clock Solar Power

Thermal modeling enabled the optimization of a critical drainage system for Archimede, the first Concentrating Solar Power (CSP) plant in the world to use molten salt for heat transfer as well as storage and to be integrated with an existing combined cycle gas facility.

BY JENNIFER HAND

**S**ituated on the east coast of Sicily, this innovative industrial demonstration plant uses Parabolic Trough CSP technology to generate electricity during sunny hours as well as under overcast conditions or at night. Jointly developed

Archimede incorporates 30,000 square meters of reflective parabolic mirror surface, in the shape of troughs. The sun's rays are concentrated onto long thin tubes, which together make up a receiver pipeline running along the inside of the curved sur-

(464° F) so that it melts and can pass into the tubes. Once it is molten, it is heated further by the sun and channeled to a dedicated steam generator where it produces high-pressure steam that drives a turbine in the adjacent combined-cycle power plant.

**“The annual solar-to-electricity conversion efficiency is over 15% better than other CSP plants.”**

### The Molten Salt Advantage

Mainly located in the US and Spain, there are several CSP plants already in operation. They all depend on pipes filled with diathermal oil to absorb solar heat and older CSP plants can only operate in the daytime under direct sunlight. Newer plants have extended their operating hours through the use of molten salt as a medium for storing heat in large, well-insulated tanks.

by Italian utility ENEL and the Italian National Agency for New Technologies ENEA, it began operating in July 2010 and is named after the mathematician and engineer Archimedes who lived in the nearby town of Syracuse.

faces and stretching for 5,400 meters. This pipeline contains a heat transfer fluid made of 60% sodium nitrate and 40% potassium nitrate, commonly used as fertilizer.

During the start-up of the power plant this mixture is heated to at least 240° C



Using molten salt for heat capture as well as storage has several advantages over pressurized oil. Molten salt operates at 550° C (1022° F) compared with oil at 390° C (734° F) so power output goes up, maximizing energy efficiency and potentially reducing the consumption of fossil fuels. The annual solar-to-electricity conversion efficiency is over 15% better than other CSP plants.

Because no oil-to-salt heat exchangers are required, the solar field is completely integrated with the energy storage system and there is minimal heat loss. This means that the tanks are less than half the size of competing parabolic trough CSP technologies with the same storage capability yet they provide seven hours of thermal storage.

The cold storage tank of both technologies works at 290°C (554° F). The temperature of the hot storage tank in oil-based CSP plants is 390°C (734° F), a difference between hot and cold tank of 100°. The temperature of the hot storage tank in the Archimede plant is 550°C (1022° F), a difference between hot and cold tank of 260°C. Comparing the Archimede plant with oil-based CSP plants the temperature difference

between the two storage tanks is 2.5 times higher.

Salt is clean and one big advantage is that once it has been cooled it can be reused. Oil degrades, is flammable and, as a toxic substance, needs to be disposed of carefully. In addition, molten salt allows the steam turbines used in the CSP process to operate within the standard pressure and temperature regulations at which fossil fuel plants run. This provides the potential for conventional power plants to be integrated easily with CSP plants like Archimede.

### Conjugate Heat Transfer Simulation

Unfortunately the advantages of molten salt also present a technical challenge:

to maintain the salt's liquid state. Daniele Consoli, Project Engineer in the Engineering and Innovation Division of ENEL, explains, "At 220° C (428° F) salt is frozen. It melts at 240° C (464° F) and in order for it to remain liquid it must be kept at 290° C (554° F). When molten salt acts as the heat transfer fluid circulating in the tubes in which irradiation is concentrated, the pipes must be able to withstand constant heat up to 300° C (572° F) degrees to prevent the salt solidifying and causing an obstruction. An electrical trace system is therefore required to preheat the pipeline and to facilitate the emptying of the circuit which drains the solar collector." Accordingly, the Research Division of ENEL chose to make the pipeline from a stainless steel alloy to withstand extremely high temperatures.

"This is an experimental power plant and there have been some critical points throughout the project," continues Daniele Consoli. "COMSOL Multiphysics has helped us to solve technical issues as they arose, for example when we needed to analyze temperature and heat loss throughout the drainage circuit and optimize both its geometry and insulation properties." The team created a model of the drain

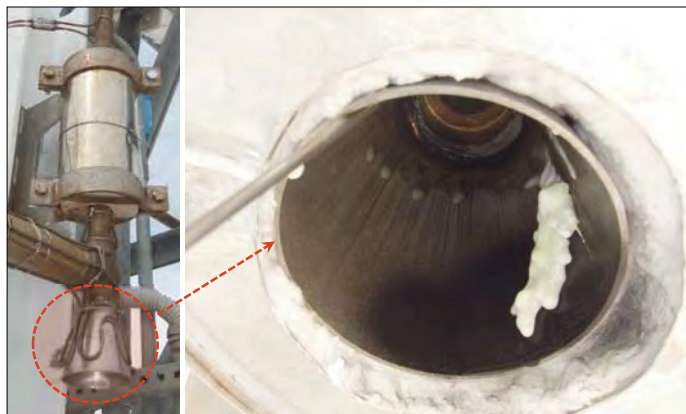

Figure 1. Drainage system and detail of conic shape drain

(Figure 1) within COMSOL Multiphysics and the results (Figure 2) were quickly validated by a physical investigation of thermography (Figure 3) and thermocouple measurements.

“To begin, we undertook two kinds of simulation. Firstly we created a stationary model and used it to determine the level of heating power which needed to be applied by cable to ensure that the temperature in all areas of the drainage system remained above the point at which salt solidifies. We carried out a 3D solid-fluid conjugate heat transfer simulation where both the conic drain part and the surrounding air were modeled. We considered heat transfer by conduction in the former, while both conduction and convection were taken into account in the latter. All the material properties were temperature dependent. We simulated heat loss in the remaining part of the drain by using COMSOL’s built-in library of local heat transfer coefficients. Thanks to such coefficients we saved both computational time and resources without affecting the accuracy of the simulation.”

The team then created a second, dynamic, model to study the transient heating of the drain and check the time required to achieve the desired temperature.

Another example of COMSOL application in CSP plant analysis has been the development of a model of the storage system to assess how, after validation, it could be optimized for plants of a larger size. This may incorporate several thermal bridges which would have to be assessed in order to avoid the potential for significant and costly thermal power losses. Daniele Consoli explains how heat transfer was modeled, “We considered heat transfer by conduction along the thickness of the wall (steel, insulation, aluminium sheet) and the foundation of the tank. We took both conduction and convection into account for the fluid (molten

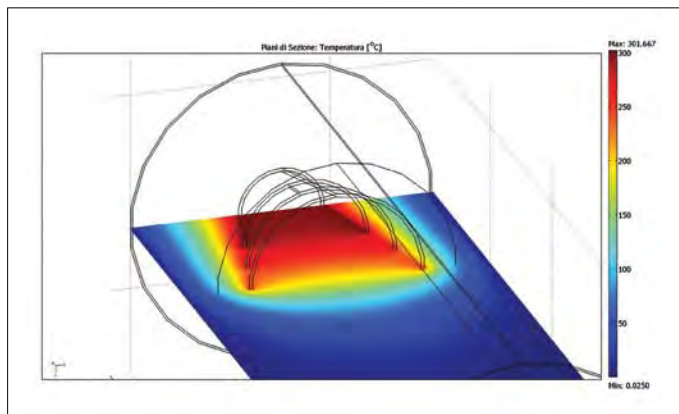

Figure 2. COMSOL simulation of the conic shape drain (the temperature field expressed in °C is shown).

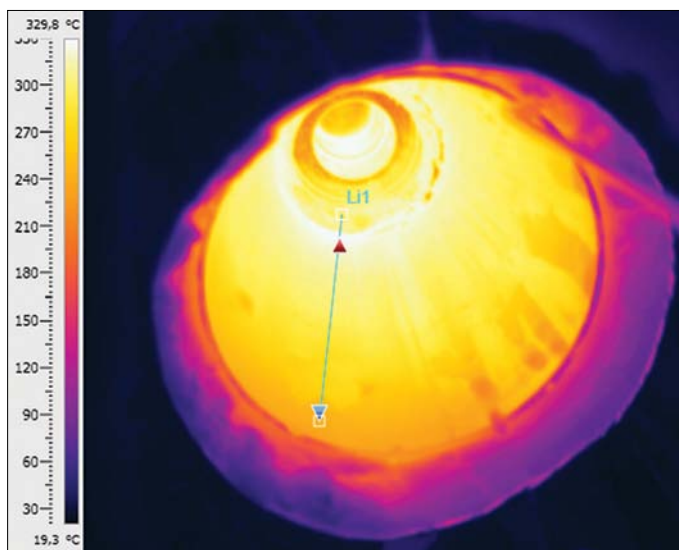

Figure 3. IR Thermography of the conic shape drain.

salt) and convection and radiation for the surrounding air outside the tank.”

### Reliable Process Operation

Given the over 50 million Euro ENEL total investment in the Archimede project, it was not difficult for Daniele Consoli to propose a business case for COMSOL Multiphysics. “Being able to simulate plant operation related to design choices on critical components was extremely important. In the case of the drainage circuit, simulation may significantly reduce the risk of potential damage to the power plant and the consequent costs in case of failures. COMSOL Multiphysics represented an appropriate tool for those analyses.”

From the operating and maintenance point of view the drain represents a single point of failure. “If it failed we would have

“Being able to simulate plant operation related to design choices on critical components was extremely important.”

to stop one branch of the plant from producing energy whilst we undertook a repair operation. Then we would need to follow complex procedures in order to reactivate the affected branch, a process that takes at least 2 working days. All this would result in the loss of tens of man-hours, significant operational income, and above all, clean energy. In addition, being aware of the thermal stresses that the drain and the whole plant are subjected to, we can schedule the preventive maintenance in a more effective way.”

According to Daniele Consoli another way to have sized the heating cables would have been via an iterative process based on experience and on monitoring the effectiveness of incremental changes in an empirical way. “With COMSOL we quickly discovered the exact amount of thermal power required and then validated the results directly.”

The Archimede project has attracted great interest from utility companies within Europe and around the globe. Daniele Consoli again, “We were building the first power plant in world to use this technology and we needed to get the first plant right and then go on to improve it. There are many potential opportunities for solar thermodynamic technology and the next Parabolic Trough CSP may be much larger. As the technical challenges may also be bigger we will continue to employ COMSOL Multiphysics.” ■

**REQUEST A FREE  
TRIAL TODAY!**

[www.spaceclaim.com/comsol](http://www.spaceclaim.com/comsol)

# SPACECLAIM: 3D Direct Modeling for COMSOL Users

SpaceClaim® is a fast and easy 3D modeler that creates ideal geometry for simulation. Our customers report that SpaceClaim removes the geometry bottleneck from setting up simulations, allowing them to run twice as many as before.

## Features:

- >> Extremely fast model creation for your simulations
- >> Open native files from most CAD systems
- >> Clean up poor data using the geometry repair tool
- >> Remove rounds and small features and merge or delete small faces
- >> Extract volumes, midsurfaces and beams with ease
- >> Parameterize and optimize imported solids easily, regardless of origin
- >> Convey changes and feedback using 3D markup tools

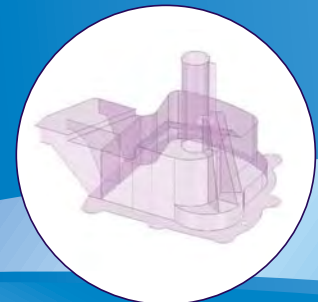
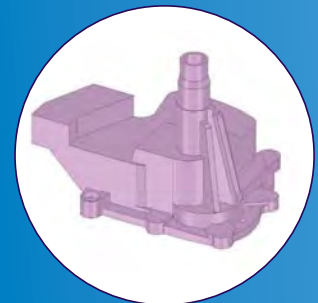
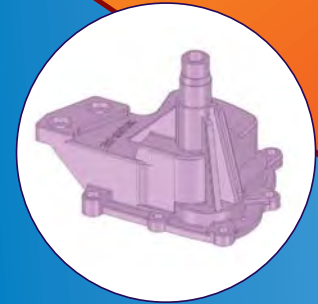

*“I am saving at least 10 hours per model analyzed  
and I am able to get results more quickly than I had anticipated.”*

— Mads Jakob Jensen, Widex, SpaceClaim and COMSOL user

Toll Free: 800-636-6004 +1-978-482-2148 [sales@spaceclaim.com](mailto:sales@spaceclaim.com)

© Copyright 2011 SpaceClaim Corporation. SpaceClaim is a registered trademark of SpaceClaim Corporation. All other names mentioned herein are either trademarks or registered trademarks of their respective owners.



Visit Us Online at [www.spaceclaim.com](http://www.spaceclaim.com)



# Modeling Electromagnetic Waves in the Thermonuclear Fusion Plasmas of the MIT Alcator C-Mod Tokamak

BY O. MENEHINI, S. SHIRAIWA, M. GARRETT, MASSACHUSETTS INSTITUTE OF TECHNOLOGY, CAMBRIDGE, MASSACHUSETTS

**F**usion is a form of nuclear energy which has impressive advantages from the point of view of fuel reserves, environmental impact and safety. If successful, fusion energy would ensure a safe, resource conserving, environmentally friendly power supply for future generations. To achieve this goal, an international collaboration, including Europe, Japan, Russia, USA, China, South-Korea and India are building the ITER tokamak which, after 10 years of construction, will advance fusion researchers' goal of demonstrating an energy-yielding plasma on earth. A tokamak is a device using a magnetic field to confine a plasma in the shape of a torus. In an operating tokamak fusion reactor, part of the energy generated by fusion itself will serve to maintain the plasma temperature as fuel is introduced. However, to achieve the desired levels of fusion power output the plasma must be

heated in the startup phase to its operating temperature of greater than 10 keV (over 100 million °C) and additional current beyond that supplied by induction must be applied.

Heating and current drive in a plasma can be achieved by radio frequency

waves are coupled to the plasma through antennas, which must be designed to withstand extreme heat loads, forces and torques. The waves then propagate from the cool outskirts of the plasma (100 thousand °C) to the hot plasma core (10-200 million °C), where

**“The FEM approach pushes the boundary of our simulation capabilities to a new level, where the modeling possibilities are only limited by the designers’ imagination.”**

waves. If electromagnetic waves have the correct frequency and polarization, their energy can be transferred to the charged particles in the plasma. In experiments, high power (MW) mi-

they are finally absorbed. Although the underlying physics of waves in plasmas is thought to be well understood, modeling the behavior of the waves in a realistic environment is still indispensable to correctly interpret the experimental results, predict the outcome of new experiments and successfully design new antennas. However, accurately modeling RF waves in fusion plasmas is challenging and much effort has been spent in this area of research. The difficulty comes from the fact that plasma is a medium which is inhomogeneous, anisotropic, lossy and dispersive.

## Cold Plasma Modeling

Assuming that the plasma is cold greatly simplifies the problem in that the wave dispersion relation becomes local (i.e. non-dispersive) and perfectly suits FEM modeling. In particular we exploited COMSOL Multiphysics unique capability of allowing the definition of the full 3D dielectric tensor of a spatially varying me-

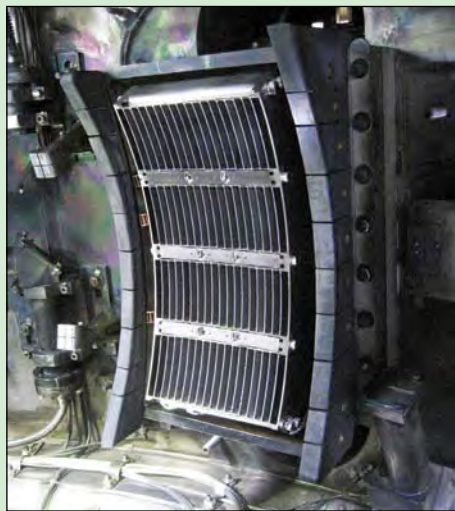

Lower hybrid grill antenna as seen from inside of the Alcator C-Mod vessel. The arrays of open-ended waveguides are phased so to launch the waves preferentially in one toroidal direction, so accelerate electrons and ultimately drive current inside of the plasma.



Ion Cyclotron antenna as seen from inside of the Alcator C-Mod vessel. Four copper straps stand behind Faraday shield rods which have the purpose of screening the electric field components which are parallel to the magnetic field lines.



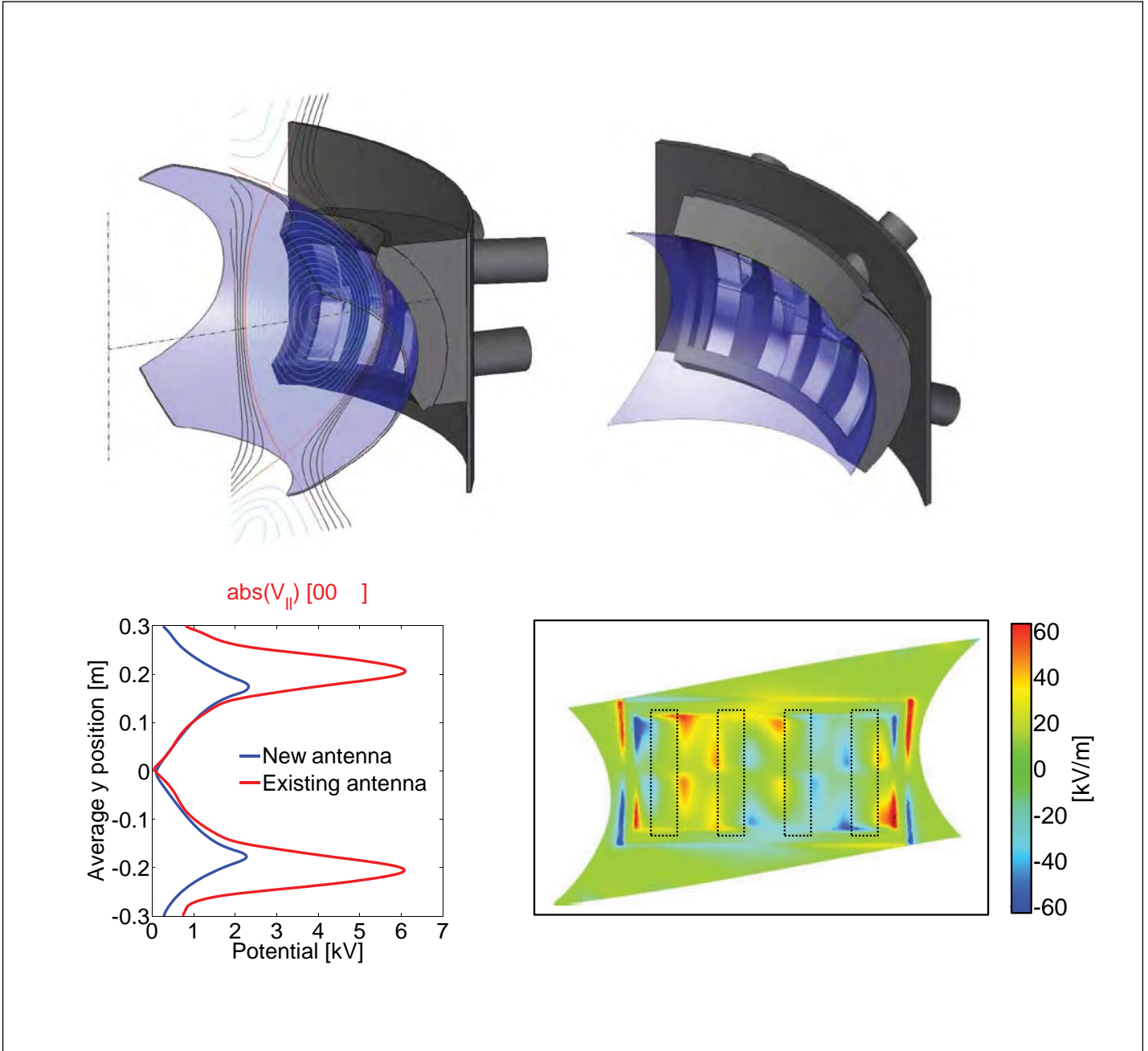

(Clockwise) CAD drawing of the rotated Ion Cyclotron antenna that will be installed on the Alcator C-Mod tokamak. Snapshot of the electric field parallel to the magnetic field lines as evaluated using COMSOL. The resulting parallel voltage was minimized with the aid of COMSOL.

dia to model the harmonic propagation of waves in a cold magnetized plasma. With COMSOL Multiphysics we were able to solve problems which were previously untreatable. We can now incorporate specific geometry, including the exact shape of the tokamak first wall and the antenna launching structures. In addition, we no longer have restrictions on the plasma description. The toroidal helical magnetic field topology and the plasma density

were directly input from experimental measurements. The new approach has been successfully validated in 1D, 2D and 3D with existing codes and has been verified with experimental measurements. This has been done for both Lower Hybrid (2 MW, 4.6 GHz) and Ion Cyclotron (4 MW, 40-80 MHz) waves, which are the two heating schemes available at the MIT Alcator C-Mod tokamak experiment. The wave propagation and heating

process in these two frequency ranges are different, and as a result also the radiating antennas at the plasma boundaries have different features. IC antennas are composed of metal loops (called straps), and fed by coaxial power lines, while LH antennas are arrays of open-ended waveguides (called grills).

For the first time, a finite element method has been used to solve the wave propagation and calculate the coupling

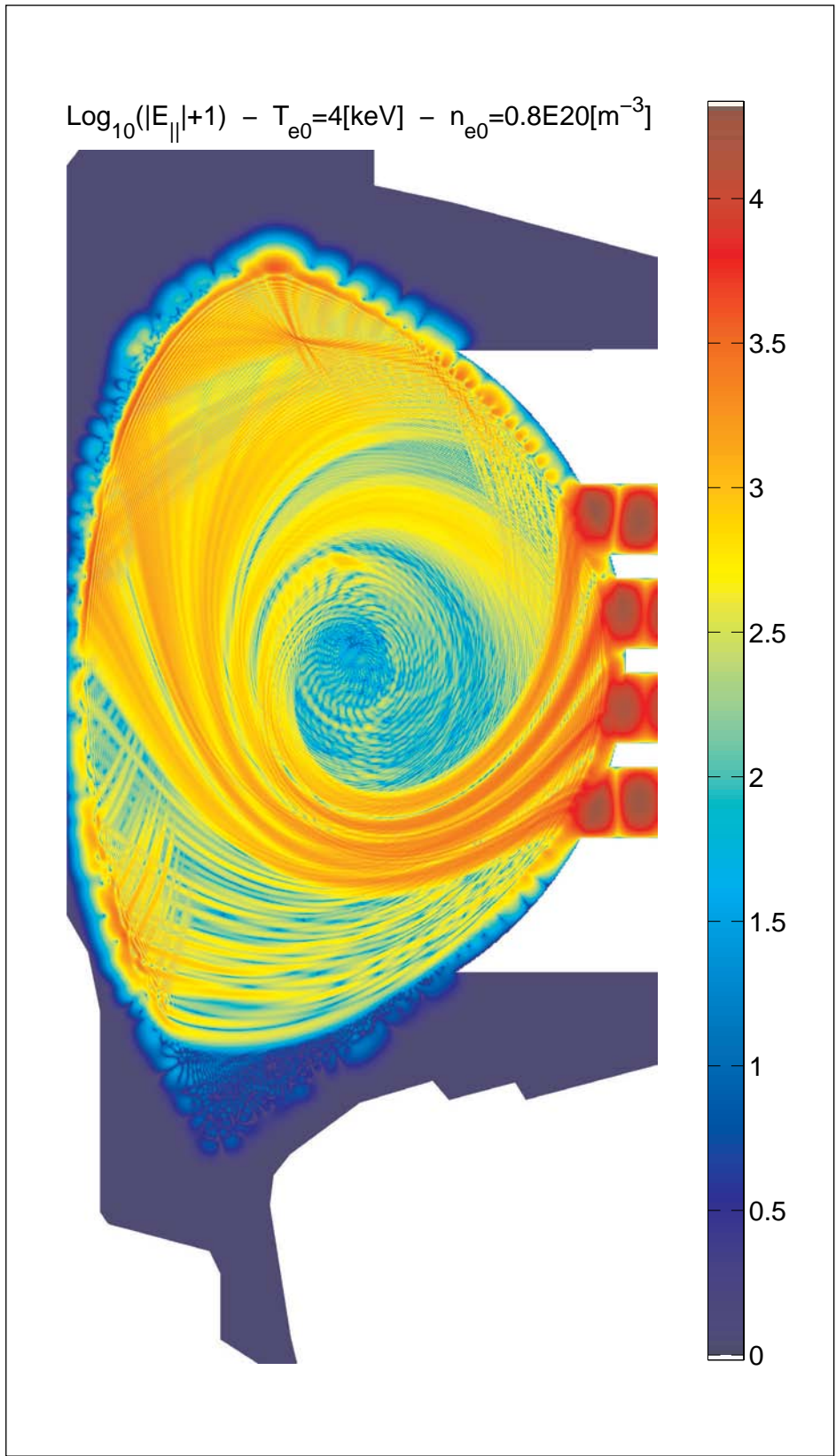

properties of plasma facing antennas for realistic fusion plasma parameters. The FEM approach pushes the boundary of our simulation capabilities to a new level, where the modeling possibilities are only limited by the designers' imagination. In this context, COMSOL Multiphysics can be used as an established, user-friendly tool which brings the design of plasma facing antennas closer to the realm of engineering. Furthermore, the integrated multiphysics environment of COMSOL allows evaluation of thermal and mechanical stresses self-consistently and within the same simulation tool, enabling faster, more efficient antenna design.

**“The integrated multiphysics environment of COMSOL allows evaluation of thermal and mechanical stresses self-consistently and within the same simulation tool, enabling faster, more efficient antenna design.”**

In particular, one of the challenges of Ion Cyclotron heating in tokamak plasmas is the production of RF driven plasma sheaths. These sheaths create large electric potentials and are capable of accelerating ions from the plasma edge into material surfaces inside the tokamak. This process can result in surface sputtering and local melting, which can introduce unwanted impurities into the plasma. Using a cold plasma model within COMSOL we are able to quantify local electric fields near the plasma boundary and try to mitigate the effects of these RF sheaths through an innovative rotated antenna design.

Result from the LHEAF code, showing the magnitude of Lower Hybrid waves parallel electric field as they propagate in a cross section of the Alcator C-Mod tokamak. The waves are launched from the antenna structure and propagate inside of the plasma, where they are damped by Electron Landau Damping. The evaluation of the EM problem was efficiently done within COMSOL.



## Parallel Computing Solves Hot Plasma Problem

Unfortunately, the cold plasma approximation does not allow for the collisionless damping of the waves (e.g. Landau damping, Cyclotron damping), which appears as a first order correction to the cold plasma approximation. These processes depend on the finite temperature of the plasma (hot plasma) and a kinetic treatment of the waves is necessary to take this into account. Hot plasma effects are spatially dispersive, meaning that the dispersion of this medium is non-local and the wave equation acquires an integro-differential form. To further complicate this model, the presence of wave fields in the plasma distorts the particles velocity distribution function, which in turn non-linearly changes the properties of the plasma. A correct evaluation of the distortion of the electron distribution function is necessary for calculating the correct wave damping and ultimately evaluating the plasma heating and current drive.

The solution of an integro-differential equation cannot be done in terms of FEM alone. For this reason, we developed an innovative iterative routine, which allows the inclusion of Electron Landau Damping (a hot plasma effect) for the Lower Hybrid frequency range. As described in [Meneghini O., Shiraiwa S., Parker R., *Physics of Plasmas*, 2009, 16, 090701] this approach allows the original integro-differential equation to be split into a conventional PDE (which can be solved by a conventional 3D FEM solver) and an integral. In this case, the ability of COMSOL Multiphysics to interface with MATLAB has been key, since it allowed seamless inclusion of the solution of the EM problem into the iteration loop. In addition, other modules have been added to the iteration, including 1D, 2D and 3D Fokker Plank codes for the self-consistent calculation of the electron velocity distribution function and a Hard X-Ray synthetic diagnostic which has been extensively used to validate the code with experimental data. A new technique to perform single mode analysis in a 3D FEM solver was also developed. Thanks to the versatility of



From the left, Syunichi Shiraiwa, Orso Meneghini, Mike Garrett and in the background the Alcator C-Mod tokamak.

COMSOL we were able to implement such custom toroidal periodic boundary conditions by means of its extrusion coupling variables. The new Lower Hybrid simulation code has been codenamed LHEAF (Lower Hybrid wave Analysis bases on FEM).

In the particular case of LH waves, the wavelength arising from the propagation in a plasma is rather short (~mm) compared to the device size (~m), thus making the electromagnetic problem very large. The significant reduction of computational requirements of the FEM method allowed us to run most of our simulations on a desktop computer, compared to full wave integral methods which routinely require access to large computer clusters with thousands of processors. However,

large simulations with 15 to 30 million unknowns required a slightly different approach. Through COMSOL Multiphysics MATLAB interface, we directly accessed the FEM matrices and inverted them with the aid of the MUMPS library, using the massive parallel computing resources of NERSC. This is yet another example of the flexibility which COMSOL Multiphysics gives to savvy users. Worth mentioning is that both the MUMPS solver and the cluster computing capabilities have now become readily available in the newest version of COMSOL Multiphysics. ■

### ACKNOWLEDGEMENTS

This research was supported by the US Department of Energy under agreement DE-FC02-99ER54512.



## World's Leading Material Reference

MatWeb is a free searchable database of property information for over 80,000 engineering materials, including:

- **Engineering Polymers**
- Ceramics
- Lubricants
- Wood
  
- **Metals and Alloys**
- Inorganic Salts
- Fibers
- Many other Engineering Materials

## Premium Feature: Import Data into COMSOL!!

Save valuable time as you find the EXACT material you need for your simulation in MatWeb's database of over 80,000 material datasheets, then transfer the RIGHT data in your COMSOL analysis with a few clicks.

Visit [www.MatWeb.com/COMSOL](http://www.MatWeb.com/COMSOL)  
for more details.

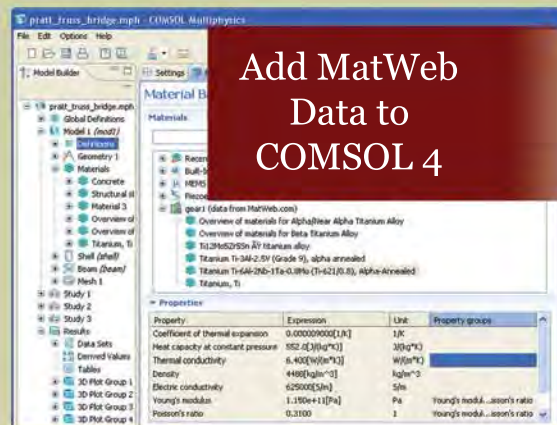

COMSOL users can now import technical datasheets from MatWeb's collection into their COMSOL material library. This is a feature of our Premium membership available for only \$99.95 for a one year subscription!

*Dear COMSOL user,*

*We are pleased to announce MatWeb has been spun off from our former parent company. Look for new and exciting products and services with the increased flexibility that this move affords. Please let us know how we can better meet your needs.*

*The MatWeb Team  
540-552-5300*

# Multiphysics Modeling Gives Developer of Small, Low-Power Biomedical Devices a Competitive Edge

Enables better, faster analysis of tightly coupled physical domains.

BY GARY DAGASTINE, TECH BRIEFS MEDIA GROUP

**M**iniaturized biomedical products such as implants, tiny scientific instruments and point-of-use medical devices are giving doctors exciting new diagnostics, monitoring and treatment options. Better imaging, precise delivery of medicines to specific body regions and mechanical augmentation of organ functions are just some of the ways these technologies are helping to advance the practice of medicine and human health.

Yet these products are complex and their development poses a host of vexing design challenges, not the least of which are the need for adequate power supplies and the diversity and variability of human tissue in which the devices must operate.

These are precisely the types of challenges that Scientific & Biomedical Microsystems LLC of Columbia, MD is focused on, with core capabilities that include micro-electro-mechanical systems (MEMS), microfluidics, embedded systems, preci-



Figure 1. The Scientific & Biomedical Microsystems team includes (clockwise from lower left) Jennette Mateo, physicist; Brian Barbarits, electrical engineer; Brian Jamieson PhD., president; Rohan Pais, mechanical engineer; Chintan Parekh, electrical engineer; Anik Duttaroy, mechanical engineer; and Andrea Pais, process engineer.

sion machining, biosensors and wireless sensor networks. The company's capability to span this entire range sets it apart from competitors, which tend to be either R&D services firms lacking the ability to do miniaturization, or MEMS foundries which are mainly focused on production (Figure 1).

**“Much of our customer base consists of startup companies, and their whole value proposition is to get to market first.”**

sion machining, biosensors and wireless sensor networks.

SB Microsystems provides a full scope of early-stage product development services to customers who are developing new biomedical products, from concept development and detailed design all the way through to prototype fabrication,

test, and manufacturing. The company's capability to span this entire range sets it apart from competitors, which tend to be either R&D services firms lacking the ability to do miniaturization, or MEMS foundries which are mainly focused on production (Figure 1).

COMSOL Multiphysics give us the capability to help them accelerate the product development process, to keep costs low and to meet their goals.”

## Acoustic Data Communications Channel

A case in point is a project to design and build a high data-rate intrabody acoustic communications channel and 360° scanning imager for Innurvation, Inc., a developer of improved diagnostic tools for diseases and disorders of the gastrointestinal tract.

SB Microsystems and Innurvation have developed the first working prototypes of an acoustic channel that will initially be used for capsule endoscopy.

That is, to build a better imaging pill for bowel screening.

The major system elements are the imaging pill itself; a portable data controller with sensors that stick to the abdomen and resemble EKG pads and leads; and software for data analysis (Figure 2).

The pill is swallowed by a patient after appropriate preparation prior to the procedure. As it travels through the gastrointestinal tract, it will continuously capture images using the scanning imager. This data then will be transferred to the data controller via the acoustic communications channel. The data controller is a small, lightweight device worn by the patient throughout the procedure. It stores the data on a memory card, then transmits it via cellular technology to an Internet-based server which the doctor can log into immediately in order to review the results.

The system employs acoustic waves for intrabody data transmission. RF technology is the traditional method used for this,

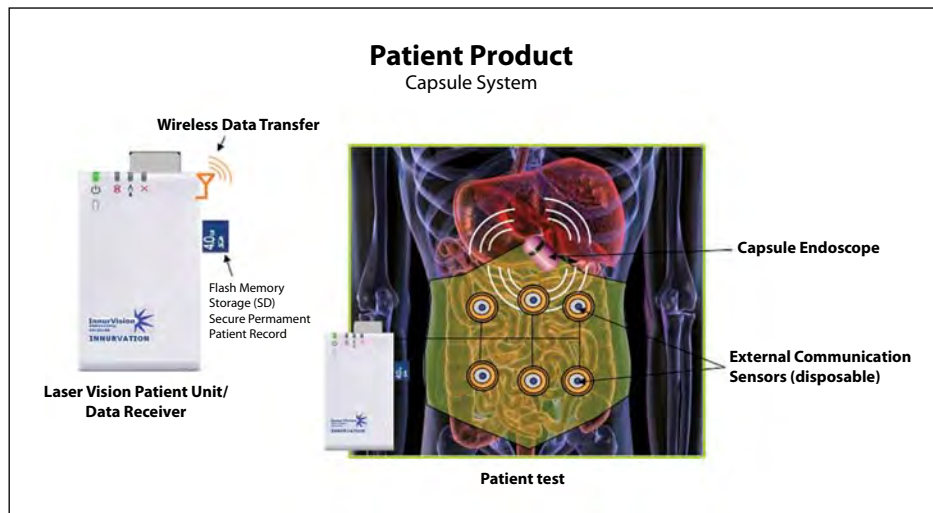

Figure 2. The new endoscopy system incorporates a smaller, more energy-efficient imaging pill with scanning imager; a portable data controller with sensors that stick to the abdomen and resemble EKG pads and leads; and software for data analysis.

but RF's power demands severely limit the power available for use by miniaturized devices. They also reduce battery life and require larger pills than might otherwise be possible. Energy inefficiency is a major reason why current imaging pills feature a resolution of only about 70 kilopixels, running at two frames/second. The resulting images are often disjointed and herky-jerky, especially when the capsule is being propelled quickly as happens during a bout of peristalsis.

By contrast, SB Microsystems is helping Innurvation develop a data channel with a 1 Mb/sec data transmission rate and a longer-life imaging pill with a 360° radial scanning imager that together will enable much sharper, continuous imagery (Figure 3).

The communications channel has been tested successfully in pigs and is moving to human trials this year, while the scanning imager is a later phase of the project.

"The human body is basically a big bag of salt water and there are many situations and sets of conditions where transmitting data via acoustic waves through this medium is very energy-efficient," said Jamieson. "Traditional endoscopes with a high-resolution CMOS imager at their tip produce really sharp images. The goal here is to achieve high-resolution endoscope-type clarity and coverage in a imaging pill."

In the system under development, the acoustic wave source is a piezoelectric

(PZT) element. SB Microsystems is using COMSOL's piezo-acoustic tools for multiple aspects of this project, from optimizing the behavior of the PZT acoustic source, to exploring acoustic interactions with different tissues, to implementing multiple receiver network designs in order to minimize multipath interference (Figure 4).

"These issues have required us to develop an understanding of the coupling between the acoustic, electric and mechanical domains, and the integrated, expert physics capabilities of COMSOL Multiphysics have been absolutely criti-

**"Since each fabrication run of these devices takes many weeks and thousands of dollars, the modeling we've been able to do has been critical in keeping this project moving forward aggressively and on budget."**

cal to the success of that effort," said Jamieson. "For example, by coupling the piezoelectric and pressure acoustics user interfaces we were able to optimize PZT material choice and sensor geometry to design a transmitter that is very nearly omnidirectional, a critical requirement."

Coupling the pressure acoustics and mechanical domains, meanwhile, enabled the design team to analyze the interactions of acoustic signals with different tissues, which provided the ability to understand and to accommodate important issues such as multipath interference and signal fade.

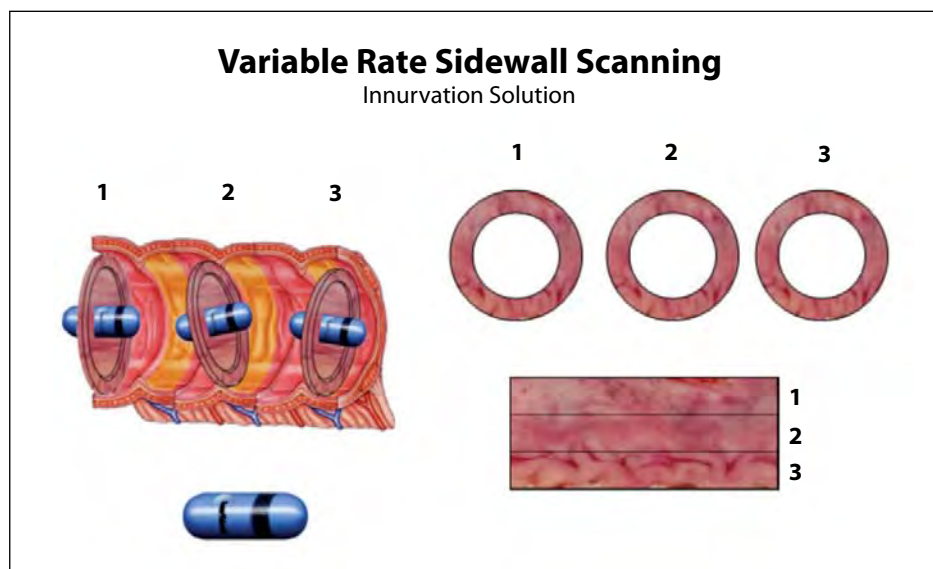

Figure 3. 360° radial scanning technology produces much sharper and continuous imagery.

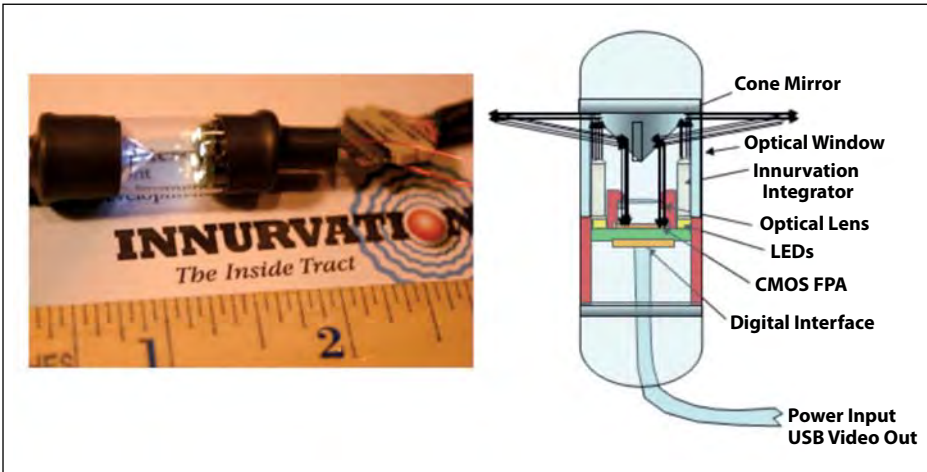

Figure 4. A tethered prototype version of the new imaging pill, showing the sidewall scanning optics. In its commercial implementation, the imaging pill would be approximately the same size as existing imaging pills, about 25-mm long x 12-mm in diameter.

### Neuron Circuitry

Another area where SB Microsystems has relied upon COMSOL Multiphysics to play a key role involves research into neuron circuits at Howard Hughes Medical Institute, where a team of systems neurophysiologists are exploring how such circuits work. It turns out that when 480 nm (blue) light shines on a neuron in vivo which contains a particular protein, channelrhodopsin, the neuron fires.

To take advantage of this operating mechanism the researchers are fabricating an extra-cellular stimulating/recording array composed of small metal

electrodes (Figure 5). Key to this array are micro-fabricated waveguides used to transmit blue light to the neurons, integrated with an optical source.

SB Microsystems is using COMSOL Multiphysics to develop these waveguides on narrow penetrating silicon needles. The software first was used to model the effect of residual film stress on the needle in order to optimize the fabrication process to produce a flat, unbent needle. It also was used to model not just the propagation of blue light within the waveguide itself but to model what happens when the light emerges from the waveguide inside the tissue.

“Is the light shining in the right direction? How much illumination is there versus input power? How much is delivered to a specific cell? The modeling allowed us to gain an important understanding of these and other critical physical parameters and to develop a sensible design before we moved into the fabrication phase,” said Jamieson. “Since each fabrication run of these devices takes many weeks and thousands of dollars, the modeling we’ve been able to do has been critical in keeping this project moving forward aggressively and on budget.”

“Our ambition is to be the world leader in the engineering of biomedical systems where small size and low power are key requirements,” said Jamieson. “Although we get excited by actually building and testing things, we see concept development and early stage proof-of-concept as a huge part of our contribution.

“COMSOL has been a critical part of our ability to help our customers develop and implement their ideas prior to starting prototyping activities. In addition, the ability to develop accurate multiphysics models helps us to refine the design space in later stages of development, and to truly understand how prototype and even manufactured devices are performing. It is a powerful tool for recognizing the inherent links between physical domains and for working with them from the start.” ■

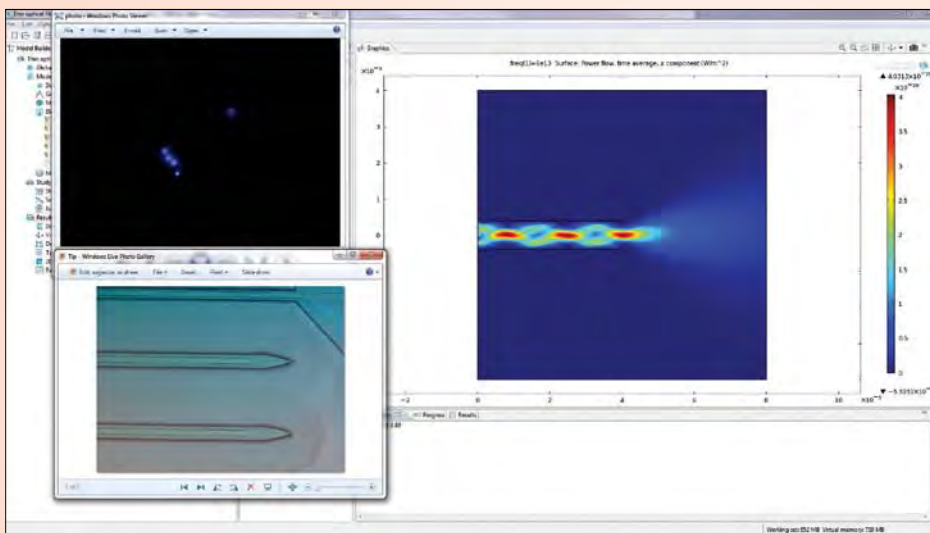

Figure 5. Scientific & Biomedical Microsystems is also using COMSOL Multiphysics to help researchers at Howard Hughes Medical Institute conduct research into neuron circuits. At right is a model rendered in COMSOL showing light propagating down a waveguide and being injected into tissue. The actual fabricated neural probe/waveguide structure is shown in a photomicrograph in the window at bottom left. The top left image shows light being split at a 4:1 switch along the waveguide.



# Expanding Multiphysics with COMSOL

COMSOL Version 4.2 expands the scope of multiphysics mechanical, chemical, and fluid simulations, as well as... For details visit: [www.comsol.com/4.2](http://www.comsol.com/4.2)

## COMSOL Multiphysics®

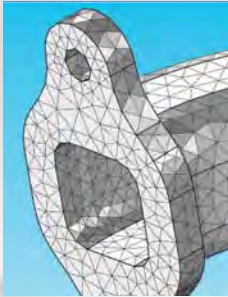

### Geometry and Mesh

Time-dependent adaptive meshing and automatic remeshing tightly link solvers and meshing algorithms for any moving mesh simulations. Models with moving diffusion fronts are solved more efficiently as are simulations involving removal and deposition of materials. New geometry tools for creating a mesh that only "sees" the essential parts of the original CAD model enable faster and more memory-efficient solving.



### Fast Parallelized Assembly and Solvers

The COMSOL direct solvers have been multi-core and cluster-enabled for several years. With Version 4.2, the multiphysics assembly algorithms and iterative solvers are also parallelized, bringing you faster and more memory-efficient computations on virtually any type of computer platform from laptop to cluster.

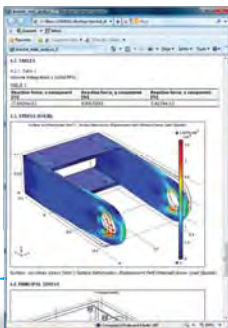

### Report Generator

The new Report Generator creates HTML reports for models. The Report Generator is an integrated part of the model, and you can add several reports to a model.

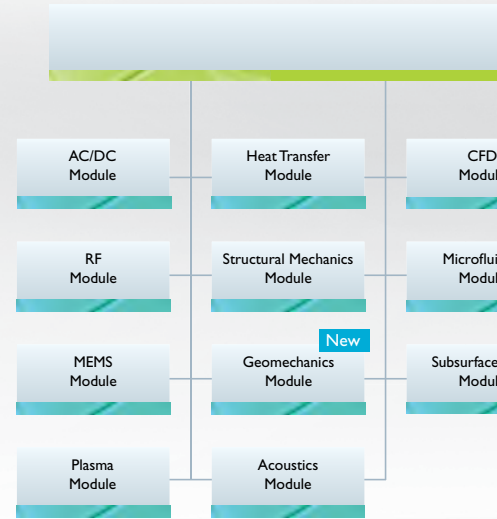

## New Modules

### Microfluidics Module

Easy-to-use tools for the study of microfluidic devices and rarefied gas flows. Important applications include simulations of lab-on-a-chip devices, digital microfluidics, electrokinetic and magnetokinetic devices, inkjets, and vacuum systems.

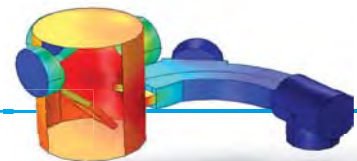

COMSOL and COMSOL Multiphysics are registered trademarks of COMSOL AB. Capture the Concept, COMSOL Desktop, and LiveLink are trademarks of COMSOL AB. Parasolid is a registered trademark of Siemens Product Lifecycle Management Software Inc. ACIS and SAT are registered trademarks of Spatial Corp. Inventor and AutoCAD are registered trademarks of Autodesk, Inc., in the USA and other countries. LiveLink for AutoCAD and LiveLink for Inventor are not affiliated with, endorsed by, sponsored by, or supported by Autodesk, Inc., and/or its affiliates and/or subsidiaries. MATLAB is a registered trademark of The Mathworks, Inc. Pro/ENGINEER is a registered trademark of Parametric Technology Corporation or its subsidiaries in the U.S. and in other countries. SolidWorks is a registered trademark of Dassault Systèmes SolidWorks Corp.



# Multiphysics Applications Version 4.2.

Multiphysics applications. Major upgrades for electromagnetic, and CAD interoperability are all within your reach.

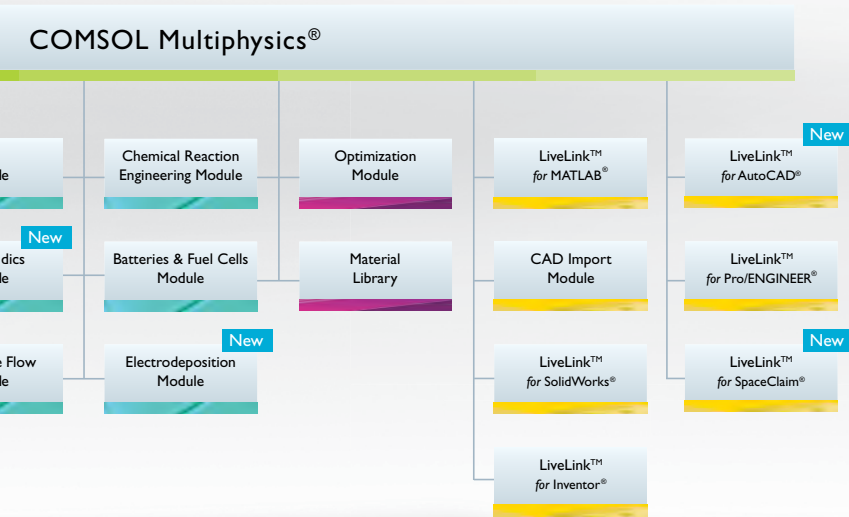

## LiveLink™ Products

### LiveLink™ for AutoCAD®

A bidirectional interface for changing the AutoCAD geometry from the COMSOL model.

### LiveLink™ for SpaceClaim®

The fusion of direct modeling and multiphysics simulation in a tightly integrated environment.

### One Window Interface in the LiveLink™ for SolidWorks®

Run COMSOL Multiphysics from within the SolidWorks user interface. The ultimate integration of CAD and simulation to accelerate product design.

## Electrodeposition Module

Model electrochemical processes for such diverse applications as chrome plating in automotive industry, e-coating, electro-coloring, decorative electroplating, and electrodeposition for PCB manufacturing.

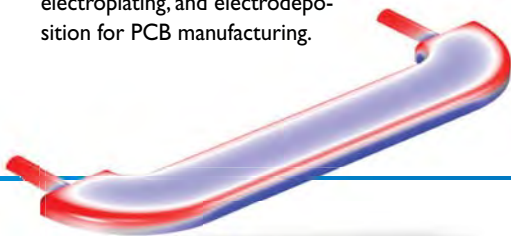

## Geomechanics Module

Simulation of geotechnical applications such as tunnels, excavations, slope stability, and retaining structures. A variety of material models for soils and rocks are provided including Cam-Clay, Drucker-Prager, Mohr-Coulomb, and Ottosen.

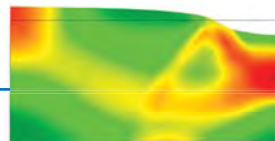

# Easy and Accurate Measurement of Blood Viscosity with Breakthrough MEMS-Based Device

Simulation-led design has put Microvisk on track to take advantage of the huge home healthcare market when it launches a hand held device that allows individuals to monitor their own blood viscosity quickly, easily and reliably.

BY JENNIFER HAND

**T**he viscosity of blood is widely regarded as an indicator of general health. When a blood vessel is damaged or broken loss of blood needs to be minimized so a series of reactions (known as the clotting cascade) begins and a blood clot is formed. A number of medical conditions adversely affect this process and in these cases patients are often prescribed an anti-coagulant such as warfarin. Health management for many of these individuals involves the weekly monitoring of blood clotting time to ensure that drug dosage is appropriate.

Existing hand held devices work by inducing a chemical reaction which is picked up by electrodes coated with compounds, a technology that has not fundamentally changed in many years. In contrast, Microvisk has developed a radical new technique that stems from futuristic research on microtechnology and harnesses the power of Micro Electronic Mechanical Systems (MEMS).

## A Completely Different Architecture

Microvisk's MEMS-based micro-cantilever devices are produced on a wafer-scale, where thousands of identical microchips are processed together as flat structures on the surface of silicon wafers. Only at the final stage of production are the micro-cantilevers released to deflect above the supporting surface, forming truly 3D microstructures (Figure 1). Such highly deformable and flexible micro-cantilevers, controlled by CMOS (Complementary metal-oxide-semiconductor) type signals, form the heart of Microvisk's unique fluid micro-probe utilized in determining the rheometric properties of minute (nanolitre volume) samples. When a current is

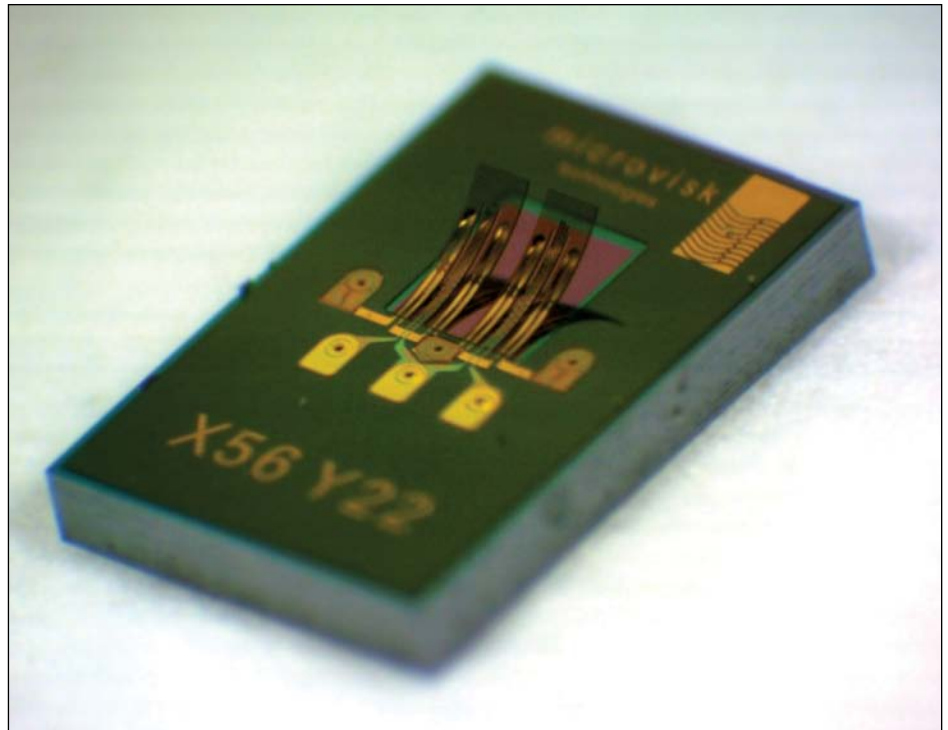

Figure 1. Microvisk's MEMS-based micro-cantilever device.

passed through the structure each layer deflects in a different way (Figure 2). As one structural layer expands more, another expands less, which leads to each cantilever moving up and down in response to immersion in a gas or in a liquid such as blood. The speed of blood clotting and its rheometric changes associated with the clotting process can therefore be monitored in a one-stage process based on physics rather than chemistry.

Dr. Slava Djakov, inventor and Sensor Development Director of Microvisk, explains why Microvisk's approach is unique. "Other cantilever designs typically used in Atomic Force Microscopy (AFM) applications or in biological research for probing and assessing DNA, protein and

aptamer bindings with drugs or antibodies, usually utilize crystalline silicon (cSi) rigid cantilevers. Because of their rigidity, cSi and similar structures are very delicate, brittle and offer restricted movement. Although cSi cantilevers can be very sensitive, through actuation in resonant mode, the restricted mobility impedes performance once these micro-cantilevers or similar structures such as micro-bridges or membranes are immersed in liquids. Through the clever choice of polymer materials we enabled the free end of the cantilever to deflect a significantly long way up from its resting position, which makes it extremely efficient and accurate in its response. We can probe for certain parameters, for example the viscosity and visco-

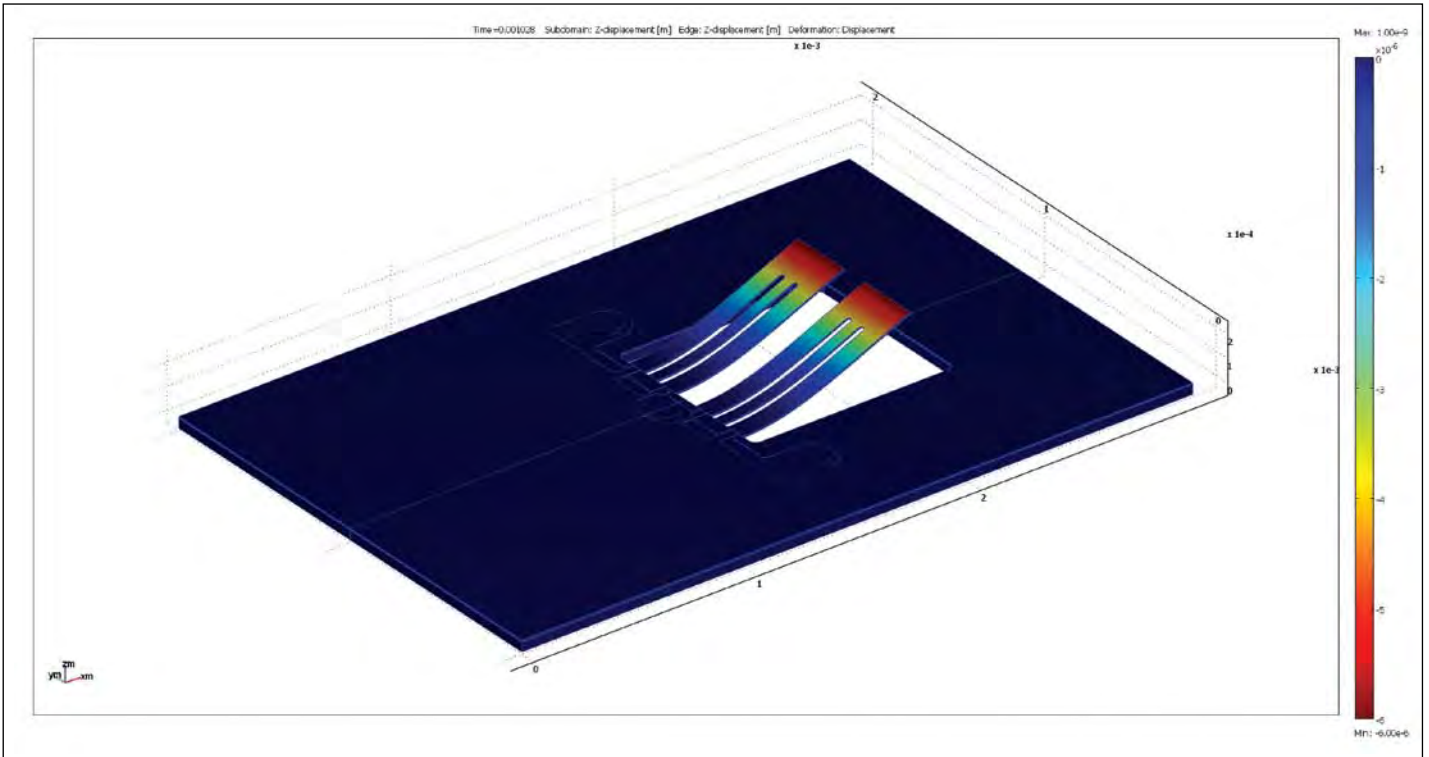

Figure 2. COMSOL model showing deflection of the micro-cantilevers.

elastic properties of blood, even at very small, sub micro-liter volumes.”

By 2004, when the company was founded and patents were applied for, Microvisk’s research team was quietly confident about the strength of the technology and its potential for use by ‘consumers’ in the convenience of their own homes. The MEMS solution could be incorporated in a hand held device (Figure 3) and the testing process was more robust than existing methods. The sample of blood required was tiny and accuracy was greatly improved. As chemicals were not needed to drive the test there was no shelf life issue and no requirement for strict storage controls before, during and after testing.

### Signals, Statistics and Synergy

The very sophistication of the technology was also the challenge. “This solution is not so much about how the cantilever moves up and down,” comments Dr Djakov (Figure 4). “It is more about a holistic approach to integration, packaging and signal processing. The big questions in MEMS-based microchip design, once the concept is proven, are how likely are the chips to perform and what are the set

points? While the standard test interrogates material electronically, we also need to consider mechanical response and reproducibility and reliability aspects such as cycling times and performance deterioration.”

This calls for an approach combining both mechanics and statics of beams systems with the thermal and electric properties of structural materials at hand.

multiphysics simulation software began to appear the company was restrained by its small size and limited financing. “We had to rely on past experience, basic know how and gut feeling. Determining the design was a long and tedious process involving laboratory experiments and real life tests.”

In 2009 he received the go ahead from the Microvisk board and management to

**“We can probe for certain parameters, for example the viscosity and visco-elastic properties of blood, even at very small, sub micro-liter volumes.”**

Complexity is further increased when a current is applied to the MEMS structures immersed in and interacting with fluids. A current not only changes electrostatic fields, it also alters mechanical structures and creates thermal effects. Dr. Djakov reports that when the research began there was no suitable modeling option and initially the team was unable to conduct multiple analyses of the MEMS. Then as

make the investment required to adopt COMSOL Multiphysics. “They were focusing on experiments only at first but now acknowledge that it was an excellent move to complement the design flow with simulation. COMSOL Multiphysics addresses all the physical properties of a design. This is not easy as we are dealing with a lot of different parameters: not only are we looking at individual mate-



Figure 3. Model of hand held device.



“By linking all the physical properties of the design COMSOL has sped up the whole process of iteration, reduced prototyping and shortened development time.”

materials which have their own unique thermal and electric properties, we also have to analyse them when they are tangled together. Which materials are the most critical and how will they behave in the presence of fluid?”

COMSOL Multiphysics enables Microvisk’s researchers to see the microchips mechanically, thermally (Figure 5) and electro-statically. They can also analyze micro fluids and their properties and how these interface with the chips and moving cantilevers. “By linking all the physical properties of the design COMSOL has sped up the whole process of iteration, reduced prototyping and shortened development time. We no longer need to solve one problem, then another and plot a graph after each step,” says Dr. Djakov.

Previously, data was collected from a number of prototyping variants of test strips then it had to be analyzed, understood and verified. One iteration typically assessed 20 different design options plus the manufacturing and assembly implications of each. Through modeling with COMSOL Multiphysics Microvisk was able to start picking out the most promising options and confirming simulation results with laboratory testing. After only fifteen months the company had completed two major design iterations and a number of optimization refinements and Dr. Djakov estimates that it had saved four to five months of development time. “Of course it is not as though we would sit and wait for four or five months but scientists would be

put on the spot to make quick decisions, perhaps without the time and resources to satisfy all their queries. COMSOL Multiphysics enables us to look at much broader possibilities and decide to investigate two or three much further. This means that we achieve a better end product at the same time as cutting development time.”

Not only has COMSOL Multiphysics enabled design optimization, it has improved the way that the development team communicates with Microvisk’s investors. Models are easily presented to the board and progress is marked using color maps and video.

### Responding to Regulatory Requirements

With medical diagnostic equipment there are stringent requirements, for example, there is a time limit on blood sample testing. Blood clotting begins as soon as a finger prick is made so the process needs to be quick. Dr. Djakov is confident that Microvisk has the best possible design. “COMSOL Multiphysics has, for example, enabled us to create a very good solution for the performance of the micro capillary channel that feeds fluid samples onto the microchips.” The whole cantilever is immersed immediately and so the test can begin, with just a quarter of the volume required by existing test devices. This means less pain for the patient. In addition there is no need to take the blood sample to the microchip; and no need to drip blood onto a certain part of a device. When

the device is held against a pricked finger for two seconds the micro capillary draws in the right amount of blood and the result is available 30 seconds later. The patient is in complete control.

### A Small Investment; a Huge Potential Return

Point of care testing and home use figure highly in the health care strategy of developed countries. The market is still emerging and according to Dr. Djakov the potential for home blood testing is similar to that of glucose testing by patients diagnosed with diabetes, a market in which 160 companies are now established.

Microvisk plans to launch the new device in the last quarter of 2011 and is al-



Figure 4. Dr. Slava Djakov, Sensor Development Director of Microvisk.

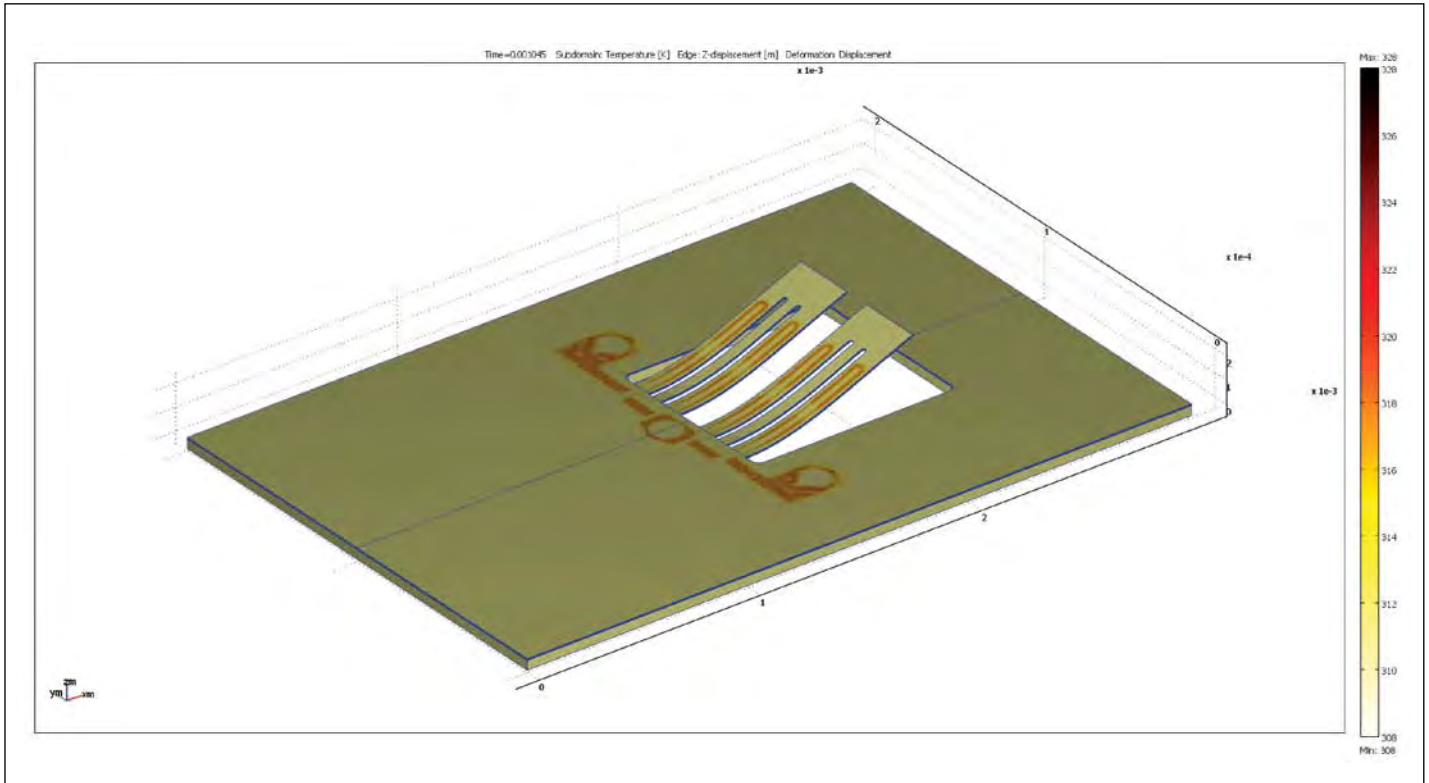

Figure 5. The COMSOL model shows accurate thermal deflection.

ready working on various add-on features.

“Once we launch we will be able to scale up very, very quickly, produce millions of microchips per month and do so cheaply. We know experts are getting very excited because they recognize that changes in blood are all driven by changes in viscosity. In due course there is nothing to prevent our microchips from performing several tests at once, our technology is already capable of handling a number of tests on one sample of blood.”

With such a large market opportunity, accompanied by low technical risk and a strong intellectual property portfolio the company expects to break even just one year after the launch of the product. “In terms of development we are right on track,” confirms Dr. Djakov. “The situation would be very different without COMSOL Multiphysics, which is giving us exactly what we need. Holistic modeling of our technology has made verification of the design much easier for my team. COMSOL Multiphysics and its MEMS module cost only £14,000 yet it has proved to be the best software for us.” ■

## Summary

- ✓ Microvisk is developing a hand held Point of Care and Home Use test for patients who are using anti-coagulant treatments.
- ✓ These devices conduct the internationally recognized Prothrombin Time/ International Normalized Ratio test by using a drop of the patient’s whole blood taken by a finger prick.
- ✓ The devices are simple to use with a clear display and large buttons. They are comfortable in the hand and the Home Use device is a discreet size.
- ✓ Microvisk’s technology takes a different approach to other devices and tests currently on the market, which use optical analysis or chemical reactions.
- ✓ Microvisk uses Micro Electro Mechanical Sensors (MEMS) on a disposable strip which incorporates a small cantilever to measure viscosity.
- ✓ As the devices use a small volume of whole blood the test is less intrusive and removes the need for a laboratory.
- ✓ The Prothrombin Time / INR test works by introducing Tissue Factor to begin a reaction known as the Clotting Cascade. This changes blood from a free flowing solution to a gel-like substance and it is this change that the sensors monitor and detect.



**LAST CHANCE TO ENTER!**

Entry deadline: June 30, 2011

# You CAN Create the Future



Calling all design engineers. It's up to you.

Share your new product ideas with the world,  
the possibilities are endless!

- Generate new jobs
- Improve health
- Increase sustainability
- Make transportation safer
- Boost security
- Advance electronics
- Accelerate productivity

SPONSORED BY

**creo**<sup>™</sup>  
A PTC Product

 **COMSOL**

**TB** TECH BRIEFS  
MEDIA GROUP

PRIZE SPONSORS

 **3DConnexion**  
A LOGITECH COMPANY



ELECTRONICS  
CATEGORY  
SPONSOR



www.createfuture2011.com

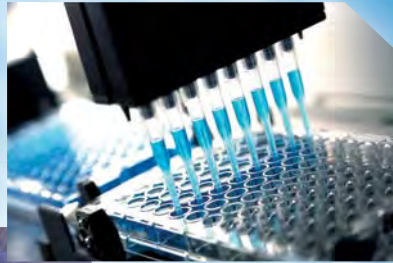

**GRAND PRIZE: \$20,000** — plus global recognition and publicity to business and industry leaders who can help bring your idea to market.

**ACCEPTING INDIVIDUAL AND TEAM ENTRIES.**

Get details at [www.createfuture2011.com](http://www.createfuture2011.com)

## CATEGORIES

- Consumer Products
- Electronics **NEW**
- Machinery & Equipment
- Medical
- Safety & Security
- Sustainable Technologies
- Transportation

# Create THE Future

DESIGN CONTEST 2011



# Optimal Wound Treatment Thanks to Modeling

BY CHANDRAMOHAN ELAMVAZHUDHI AND MOKAN MARIMUTHU, HCL TECHNOLOGIES LTD.

Treating and dressing wounds is often straightforward because these are easily accessible, but that's not always the case. One good example is surgery for sinusitis, which cannot always be cured with medication alone. Following surgery, however, the wound must be treated by spraying the nasal cavities with a special formulation that keeps the surgical wounds moist, disinfects them and provides protection against seepage of internal fluids to ensure rapid healing. However, getting a uniform coating of the right amount in all the right spots is not an easy task. To find an answer to this problem, a medical company turned to HCL Technologies — Engineering Services Group in Chennai, India, to design

nozzle into the sinus cavity with pressurized air. The design we worked on was a multi-hole sprayer with the goal of optimizing the mass flow rate and angle of spray at each hole to cover the desired area within the nasal cavity. Design optimization was carried out considering different configurations of the holes where the model inputs were the final fluid's dynamic viscosity as well as the inlet and outlet pressures.

This application differs from other nozzle designs in that the number of holes, their dimensions and locations are highly sensitive parameters; this is unlike many industrial applications where these parameters don't significantly affect system performance. Here, too, we wanted

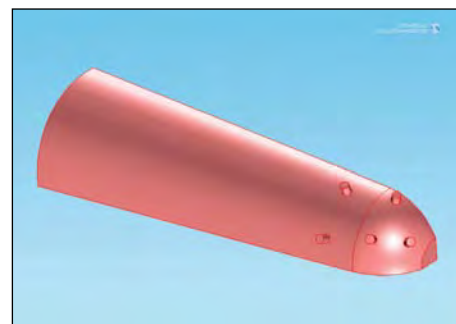

Fig. 1. A quarter symmetry of the actual nozzle geometry with a typical placement of holes modeled in COMSOL (right)

**“Our experience shows that the cost of prototype and testing drops by a third when we use COMSOL.”**

a sprayer that would meet the above requirements while using the least amount of expensive medication.

## Transformational Outsourcing

HCL Technologies is a leading global IT services company that focuses on “Transformational outsourcing”. With consolidated revenues of \$3.1 Billion, it has offices in 29 countries and provides services in vertical markets including Financial services, Telecom, Media, Retail, E&U, Public sector, Medical devices and others. HCL Technologies — Engineering Services is one of the service line and Mechanical Engineering is part of this service wing. CAE centre of excellence is a core team for product development under Mechanical Engineering.

In this application, the physician inserts the sprayer nozzle into the patient's nostrils one at a time. The sprayer mixes four phases of medicinal fluids that react to form a single phase. This is biodegradable coating is sprayed through the

to increase the flow rate, but arbitrarily adding holes would not only lead to poor spray coverage but it would also waste expensive medication.

There was no logical way to determine the best hole pattern. Previously we would have had to go to a prototype shop, have perhaps 40 to 50 prototypes fabricated and examine them in detail. Instead, we turned to DoE (Design of Experiment) ap-

proach through Minitab software and then COMSOL Multiphysics to do this study numerically. Our experience shows that the cost of prototype and testing drops by a third with the use of COMSOL, and the time needed to conduct a study of a prototype takes only a third as long.

## Sensitivity Analysis, Then Simulation

The process follows these stages. First we conduct a DoE sensitivity analysis using a Box-Behnken study implemented with Minitab software. This helps us to identify the critical factors influencing flow and determine the possible number of holes and their placement. We place restrictions on these two parameters based purely on engineering experience. The DoE analysis helps us reduce the infinite number of possible combinations to a handful

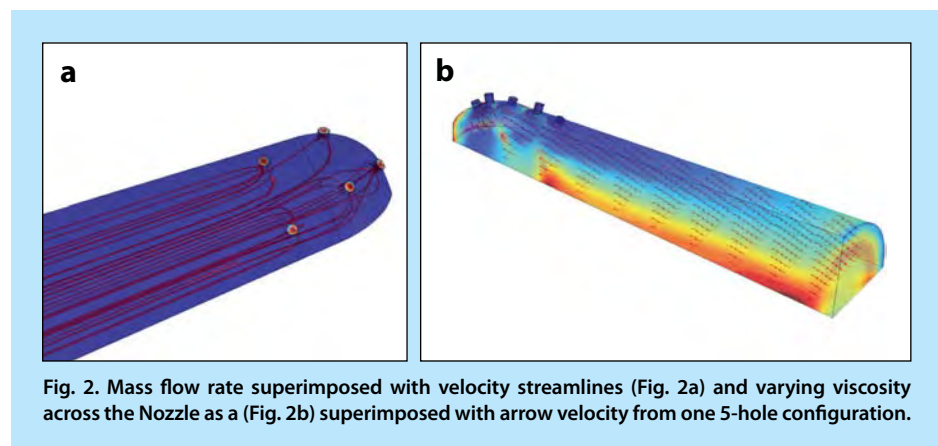

Fig. 2. Mass flow rate superimposed with velocity streamlines (Fig. 2a) and varying viscosity across the Nozzle as a (Fig. 2b) superimposed with arrow velocity from one 5-hole configuration.



of configurations that look most promising. We then construct a mechanical design of each alternative in SolidWorks and import that geometry into COMSOL for a detailed evaluation of the flow patterns, with each simulation run taking 2 to 3 hours.

We employ a 3D single-phase, incompressible, non-Newtonian, steady-state Navier-Stokes fluid flow simulation through the spray nozzle. The viscosity is specified as a function of shear rate to account for shear-thinning behavior of the medicinal fluid. The flow is considered laminar as evidenced by the characteristic Reynolds number estimates at the inlet and outlets. Only a quarter of the nozzle is modeled due to geometric symmetry. Pressure inlet and outlet conditions are used to drive the flow, and the internal nozzle wall is represented as a no-slip wall. Tetrahedral elements are used to mesh the computational domain, and a mesh sensitivity study is conducted to identify the appropriate mesh discretization beyond which the solution is invariant for further mesh refinement. A direct solver (PARDISO) is used for solving the system of linear equations.

Fig. 1 shows a typical geometry, for which we use symmetry to study just one-quarter of the total design. Fig. 2 (a) shows the the velocity streamlines from one 5-hole study, and Fig. 2 (b) shows the mass flow rate.

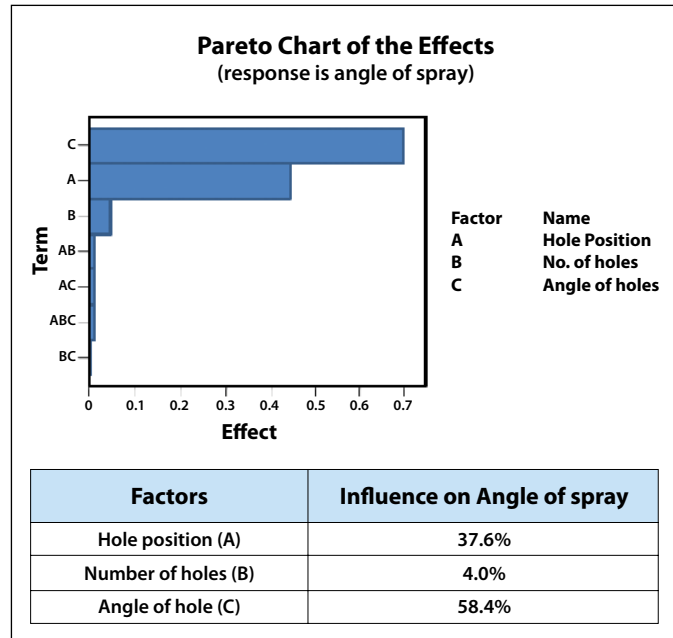

Fig. 3. Pareto chart for angle of spray showing that the number of holes plays a far lower role in the overall device’s angle of spray than other factors.

We collect information from a variety of studies and assemble the data in a table that makes it easier for us to compare results. We have discovered, for instance, that the total mass flow rate of the nozzle increases with the number of holes, whereas increasing the number of holes does not significantly affect the individual hole mass flow rate. It is also important for us to investigate the effects of the angle of each hole.

### Deriving the Transfer Function

In addition, we then prepared a Pareto chart to study the angle of spray (Fig. 3). It provides a different view of the information,

specifically the percentage influence of each design parameter on the response variable (angle of spray). With this information, we were able to devise a transfer function for the required angle of spray. With it, we can quantify the most influential design parameters. This transfer function will help in building a mathematical model for first-order evaluations of further optimizations without having to repeat a simulation; we will need to conduct a full-scale simulation only after this transfer function indicates that the work will be worthwhile.

Overall, we found COMSOL very well suited for our studies for several reasons. Firstly, due to its fast turnaround

time in both setting up and running the models. The automated adaptive grids saved us considerable time, allowing our engineers to focus on results rather than model setup. It’s also easy to change the underlying equations with the physics that describe the process.

Based on our success using COMSOL in this application, we intend to use this code for FSI (fluid-structure interaction) studies, magnetic simulations and thermal flow studies for the development of advance medical devices. ■

### LEARN MORE

[www.comsol.com/papers/9167/](http://www.comsol.com/papers/9167/)

## About the Authors

Chandramohan Elamvazhudhi received his B.Sc in Physics from Madras University and a B.Tech in Automobile from Madras Institute of Technology (MIT) Anna University. He has worked in various branches over the years including automotive, aerospace, consumer electronics, medical devices and semiconductor in R&D and service organizations. He has been with HCL Technologies for the last seven years as part of Center of Excellence, managing the Chennai division.

Mokan Marimuthu received his BE in Mechanical Engineering from Dr. Mahalingam College of Engineering and Technology, Anna University, India. He has been working in automotive and medical devices in R&D and service organizations. He is currently working with HCL Technologies on nonlinear, FSI and thermal simulations for medical device product design and verification.



The COMSOL design team at HCL’s Engineering Services Group; the authors Chandramohan Elamvazhudhi (third from the left) and Mokan Marimuthu (fifth from the left).

# Microscopic Magnetic Field Simulations with COMSOL Multiphysics

Micro-magnetic fields hold the promise of new medical treatments. Researchers turn to modeling for designing a MEMS field generator device.

BY GIORGIO BONMASSAR, HARVARD MEDICAL SCHOOL AND A.A. MARTINOS CENTER, MASSACHUSETTS GENERAL HOSPITAL

**E**lectrical stimulation is currently used as a therapeutic option for treating a wide range of human diseases including cardiovascular, sensory and neurological disorders. Despite the remarkable success of electrical stimulation, there are significant limitations to its application; these limitations include incompatibility with magnetic resonance imaging (MRI) and the association with tissue inflammation. Here, we present an alternative method that uses micro-magnetic fields instead of direct electrical currents to activate excitable tissue.

## MEMS Microinductor

COMSOL Multiphysics allowed us to estimate microscopic magnetic fields generated by a custom made micro-coil. The field estimation was performed using the AC/DC Module, which gives the ability to solve Maxwell equation for the description of electromagnetic fields with the magnetic quasi static approximation. This approximation holds when considering low frequencies and ignoring the contribution of the displacement currents. We studied the MEMS microinductor (Fig. 1) designed to create a microscopic magnetic field using a 3D model of electromagnetic quasistatic approximation.

An inductor is the ideal magnetic field generator, and it stores the magnetic field energy generated by the supplied electric current. The 3D model of the square inductor was solved for the electric and

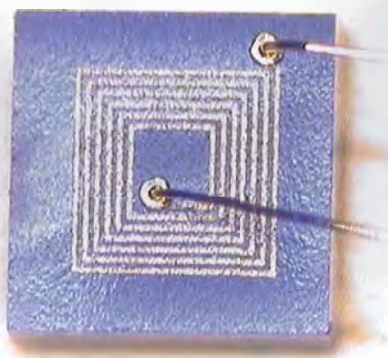

Fig. 1. Image of a  $\mu$ MS coil. The typical overall dimensions of the coils are  $350 \mu\text{m} \times 350 \mu\text{m}$ .

magnetic potentials using the Lagrange Quadratic vector with constant input current. The geometry (Fig. 2) consisted of a  $680 \times 680 \times 400 \mu\text{m}$  block, which contained three different objects: a seven-turn coil composed of gold traces (red), surrounded by air and the tissue substrate (blue). The assumption made was that no displacement currents were present. However, a capacitive component may still have been

present in our stimulation. Future studies should address this important point.

## Micro-Magnetic Fields Simulation

In setting up the model, all set the steps were performed in COMSOL Multiphysics, including: (1) drawing, (2) defining the boundary conditions, (3) meshing, (4) solving and (5) post-processing. The drawing procedure was facilitated by the existence of a similar example in the COMSOL Model Library named “Integrated Square-Shaped Spiral Inductor”. This model examines the case of a MEMS square inductor that is used for LC bandpass filters but with fewer turns than in our case. As in the example, the boundary conditions allowed for the definition of the excitation with the use of a port. The mesh was a Delaunay set with a maximum element size of  $2.5 \cdot 10^{-5}\text{m}$  on the coil domain and with the adaptive refine meshing option, generating a mesh consisting of 7,782 tetrahedral base mesh elements, and 61,685 degrees of freedom.

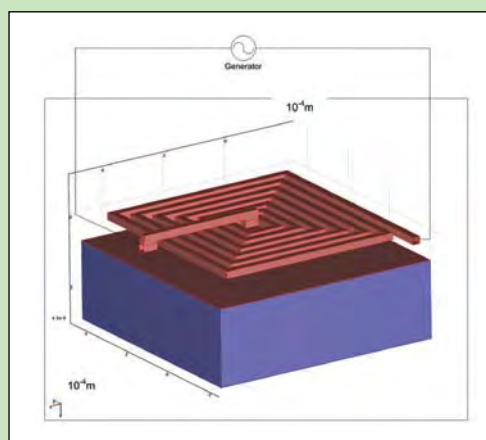

Fig. 2. Geometrical model of the 7 turns spiral square inductor (red) on top of the neuronal tissue (blue) and connected to a current generator. This model of the proposed coils was used in the Finite Element 3D studies to estimate the induced currents in the tissue (i.e.,  $50 \mu\text{m}$ ).

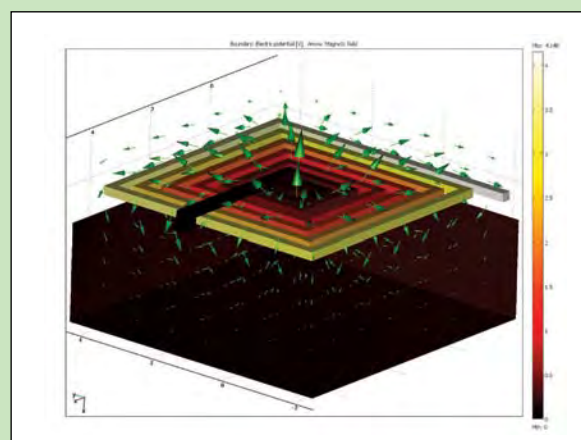

Fig. 3. Distribution of the magnetic field (arrows) generated around the  $\mu$ MS coil as predicted by the 3D FEM simulations. The size of the arrow is directly proportional to the magnitude of the magnetic field (A/m) in each (x, y, z) point of space uniformly sampled in  $7 \times 7 \times 7$  locations. The colormap represents the electric potential (V).



Giorgio Bonmassar of Harvard Medical School and A.A. Martinos Center, Massachusetts General Hospital.

The simulations converged to a stable solution after approximately 30 s (3D) of computing time on a Dell PC equipped with 2 GB RAM and a dual core Pentium P4 processor running WinXP. The 3D simulations show a magnetic vector field (Fig. 3) and an approximate 1 Tesla

peak magnetic flux density (Fig. 4) at a depth below the coil of 100  $\mu\text{m}$  and 50  $\mu\text{m}$  from the coil. Postprocessing allowed to show the magnetic field distribution in 3D using a set of 3D vectors and express the magnitude of the magnetic flux in a slice in a quite effortless manner.

Finally COMSOL estimated the self-inductance. In theory, the coil inductances can be estimated directly from their geometry using published formulas<sup>1</sup>. Each inductor tested had inductance and DC resistance consistent with the measured value ( $\pm 10\%$ ). ■

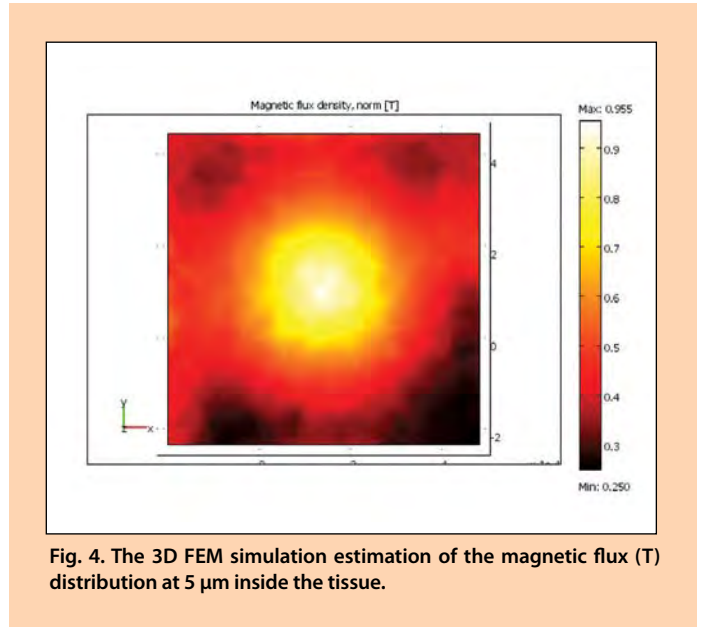

Fig. 4. The 3D FEM simulation estimation of the magnetic flux (T) distribution at 5  $\mu\text{m}$  inside the tissue.

**REFERENCE**

<sup>1</sup> Rosa, E. (1908). "The Self and Mutual Inductances of Linear Conductors." Bulletin of the Bureau of Standards 4(2): 301-344.

**FREE SUBSCRIPTION!**  
 If you do simulation-driven design, you need to sign up today at:  
[www.deskeng.com/subscribe](http://www.deskeng.com/subscribe)

# Modeling Helps Improve Safety in the Production of Teflon®

One of the most useful plastics ever discovered, Teflon®, involves a dangerous manufacturing process. COMSOL Multiphysics is helping researchers determine how to identify risky situations when designing production facilities.

BY MARTIN BECKMANN-KLUGE & FABIO FERRERO, BAM GERMAN FEDERAL INSTITUTE FOR MATERIALS RESEARCH & TESTING

We know it as the non-stick coating Teflon®, but chemists know it as PTFE (polytetrafluoroethylene). This now ubiquitous substance was discovered in 1938 by Dr. Roy J. Plunkett. This substance has since revolutionized the plastics industry and created a new branch with annual sales in the billions of dollars.

Because this substance is so non-toxic, biologically inert and has excellent resistance to chemicals, organic solvents, acids and alkalis, it is used for piping and valves for the processing of aggressive chemicals and substances.

## Dangerous in the Making

As useful as PTFE is, the polymerization process whereby TFE gas is converted into this solid can be dangerous. Not only is TFE highly flammable, it belongs to the small group of decomposable gases that are capable of exothermal reactions (those that generate heat) without the need of an oxidant. Under specific conditions that can even occur in the production process — generally when local temperatures reach the range of 500 K — an exothermic dimerization of TFE gas can start, leading to a self-heating of the gas phase. In some cases, this can in turn initiate an explosive decomposition reaction.

In an effort to help its member companies better understand how to improve safety in PTFE production facilities and prevent future accidents, for several years the industry organization PlasticsEurope has been subsidizing experimental research and the development of a mathematical model of the self heating of TFE at the BAM Federal Institute for Materials Research and Testing in Berlin, Germany. The resulting model, created with COMSOL Multiphysics, is to our knowledge the only CFD code used to study this particular phenomenon.

Until now, we have addressed this issue by conducting tests on small autoclaves

where we would determine the Maximum Ignition Temperature of Decomposition (MITD). The MITD depends on the initial pressure and on the vessel geometry; Fig. 1 shows the drawing of a 3 dm<sup>3</sup> vessel. Therefore, we would perform test for a number of initial pressure-vessel volume conditions and could interpolate between them. However, we are unable to conduct such tests on very large autoclaves of the size used in industry because of the

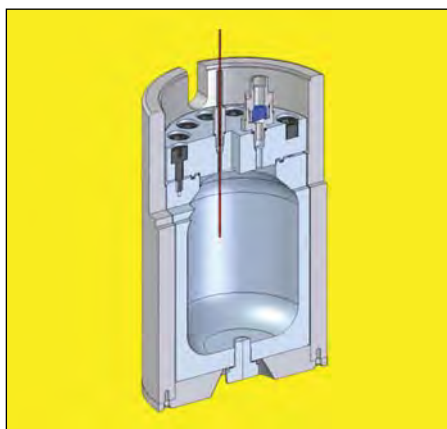

Fig. 1. Sectional view of a 3 dm<sup>3</sup> vessel used for the experiments to determine the Maximum Ignition Temperature of Decomposition for TFE.

very high effort required to deal with the amount of gas and due to the extensive setup and necessary manpower.

These restrictions led to the desire for a mathematical model that could predict the behavior of the studied phenomenon in large autoclaves. The model was designed to simulate the self-heating process of TFE so as to determine the MITD for TFE at elevated pressures. This research will therefore help reveal the critical conditions responsible for the self-ignition of TFE.

## Identifying the Key Reactions

A particular challenge in developing this model was to identify a suitable chemical reaction mechanism. Until now, research-

ers have only concerned themselves with a single reaction, the dimerization reaction where two TFE molecules “bump” into each other to create a new bigger molecule; this is the main reaction which releases energy to the gas and can result in a runaway condition if the heat builds up to critical levels. We soon learned, however, that using this reaction alone resulted in a model with poor correlation to some of the experimental results. Before you can model this decomposition reaction, you must also consider the many other reactions that begin parallel to dimerization.

Only after extensive study and research were we able to identify many reactions that took place in the heated gas phase, but we didn't know which ones were important for the self-heating that leads to the point of the explosion. This is where we first turned to COMSOL, specifically to the Chemical Reaction Engineering Module. In this software, which was very easy to set up, we included all of the dozen or more reactions we had identified as possibly being important. With the aid of the software we were able to find the six reactions that were needed for an accurate model and have confidence that we could omit the others for this particular study because they take place at temperatures above the self-ignition temperature, meaning they start only if the system is already experiencing a runaway.

However, this first simulation assumed that the reaction was taking place in a controlled environment with a perfectly mixed system and didn't account for local distributions. The results were lower values for the MITD compared to experimental ones, meaning that the results were on the conservative side. Furthermore, in this setup, no significant influence of the side reactions could be found unless the primary reversible dimerization reaction was included.

### A More Complex Model

Thus, we started to also include the effects of fluid flow and the movement of temperature to help isolate hot spots that could initiate the undesired reaction. We were also able to determine the effects of using external means to hold the wall of the reactor at a constant temperature.

In this more complex model, three physics interfaces in COMSOL Multiphysics are used. First, the non-isothermal flow interface describes the free convection caused by the different densities due to the exothermic dimerization reaction. Second, the convection and conduction interface defines the heat transfer resulting from the extended reaction net involving the six reactions under study. Third, the convection and diffusion interface represents the mass balance by linking the reaction kinetics.

Fig. 2 shows the geometry for the model and some results. A hot zone in the upper part of the vessel is clearly visible; this is due to the buoyancy effect generated by local temperature differences which are created by the heat of the dimerization re-

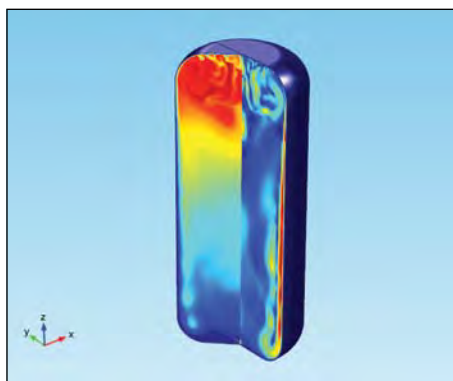

Fig. 2. Temperature (K) in a 3-dm<sup>3</sup>-vessel, shown in the left cross-section, after 21 s; note the hot zone building up in the upper section. The cross-section at the right shows the complex velocity field caused by free convection in the vessel.

action. There are also several small downward streams which form at the top and move to the walls where they disappear. In fact, even if at the beginning of the process the walls are the hottest area where the dimerization reaction is initiated, once the hot dense gases move toward the top, the walls become a cooling function. This cooling effect at the walls produces turbulence in the gas leading to a continuous supply of non-reacted TFE from the lower part of

the vessel to the hot upper reaction area. Beside the pressure the dimerization reaction strongly depends on the temperature and in the hot zone a self-accelerating process takes place.

Validation of the model was done by comparing the experimentally determined MITD with the simulated MID given by the model (figure 3), and good agreement was found.

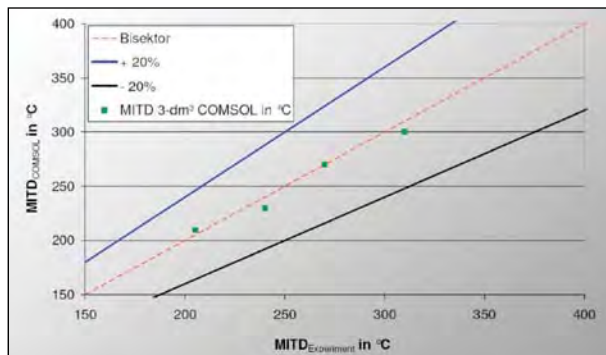

Fig 3. Direct comparison of the MITD for a 3 dm<sup>3</sup> vessel at various temperatures showing how the experimental and simulated temperatures are very close across a wide range.

### Industrial-Sized Reactors

We are now embarking on a series of validation tests using industrial-sized reactors. The benefits of having a validated model are plentiful. Companies could determine if for a given reactor a specific pressure/temperature setting is not safe and consequently adapt the process. Plant engineers could use the model to determine if and how they should change their process conditions. Furthermore, with a working model we can study additional aspects such determining the geometric dependence of the self-ignition temperature. Finally, we can study forced convection, add piping of various diameters, different flow regimes and vessels orientations as well the effect of internal features/obstacles. ■

### ACKNOWLEDGEMENTS

The authors would like to gratefully acknowledge the following persons for their assistance in the research described in this article: V. Schröder of the BAM German Federal Institute for Materials Research and Testing and A. Acikalin and J. Steinbach at the Technical University Berlin. Moreover, many thanks go to PlasticsEurope and the TFE Safety Task Force and their members. Without their financial support and the supply of good ideas, plenty of information and, of course, TFE this project could not have been realized.

### LEARN MORE

[www.comsol.com/papers/8717/](http://www.comsol.com/papers/8717/)

## About the Authors

Martin Beckmann-Kluge is a process engineer at BAM German Federal Institute for Materials Research and Testing. He earned a degree at the University of Applied Sciences in Wildau and is working on his PhD thesis at BAM in the Chemical Safety Engineering working group in cooperation with the Department for Plant and Safety Engineering of the Technical University Berlin.

Dr. Fabio Ferrero is a researcher at the BAM German Federal Institute for Materials Research and Testing. He received a degree in Chemical Engineering at the Politecnico di Torino in Italy and then his PhD from the Universitat Politècnica de Catalunya in Barcelona for work on hydrocarbon pool fires. He started his career at BAM in 2007 and has since dealt with different aspects related to the safety in chemical plants including research topics addressing decomposable gases such as TFE and acetylene.



The authors Dr. Fabio Ferrero (left) and Martin Beckmann-Kluge (right) standing in front of an autoclave.



© ESA - D. DUCROS 2003

# Reduced-Weight Reaction Sphere Makes Way for Extra Satellite Payload

BY LEOPOLDO ROSSINI, EMMANUEL ONILLON, AND OLIVIER CHÉTELAT, CSEM SA, SWITZERLAND, WWW.CSEM.CH

**W**hen launching satellites to orbit, every gram of payload is extremely valuable. Depending on the orbit and the launcher, an estimated cost is about 15,000 euros per kilogram. With this in mind, researchers at CSEM, the Swiss Center for Electronics and Microtechnology, are working on ways to minimize the weight of satellite attitude control systems. Here, a single multi-axis reaction sphere is proposed to replace four conventional single-axis reaction wheels. Its geometry and electromagnetic design are quite complex, and only with the help of COMSOL Multiphysics are they able to examine various configurations of magnets to find the one that works best.

Founded in 1984, by grouping three former watch-industry research laboratories, CSEM is today a private applied research and development center specializing in microtechnology, system engineering, microelectronics, and communi-

cation technologies. With headquarters in Neuchâtel, it has some 400 employees in Switzerland.

## Until Now: Multiple Reaction Wheels

In conventional 3-axis stabilized spacecrafts, three reaction wheels are arranged along the three axes, with a fourth wheel for optimization and redundancy; they are normally employed to implement attitude control systems with the required accuracy and without using fuel to fire jets. This attitude control allows the satellite to be pointed towards an object in the sky, towards a particular location on earth or to stabilize the satellite by compensating for disturbances it might encounter.

The operating principle is relatively simple: an electric motor is attached to a flywheel. If the wheel accelerates, it builds up angular momentum in a certain direction, and the spacecraft rotates

in the opposite direction due to the law of conservation of momentum. Note that such a device can only rotate a satellite around its own center of mass and cannot be used to move the spacecraft to a different position.

The researchers at CSEM are operating under the assumption that the work of three reaction wheels can be done with one reaction sphere. That device is an iron ball covered with permanent magnets and held in position with magnetic levitation through magnetic fields generated by a number of electric coils. The sphere, acting as a rotor, is accelerated about any axis of rotation with a 3D motor. An attitude control system based on a reaction sphere would be smaller and lighter than those based on reaction wheels; even with its more complicated control electronics, it is estimated that the device can significantly increase the torque in the same volume. In addition, due to its magnetic bearing,





“An attitude control system based on a reaction sphere would be smaller and lighter than those based on reaction wheels”

the reaction sphere is expected to generate less micro vibrations due to the absence of ball bearings and lubricants. Finally, the possibility of using it as a multiple degree-of-freedom active vibration damper to absorb external disturbing forces is another attractive feature.

The concept of spherical actuator is not new and has been known for roughly 30 years. They have been used in robotics for spherical joints such as to mimic the wrist. However, this is believed to be the first application of spherical actuators in satellite technology.

### 728 Permanent Magnets

A project funded by the European Space Agency was started in 2005 to investigate the viability of a reaction sphere for use in space. CSEM's patented design is based on a 3D permanent magnet motor implemented with a multi-pole rotor and a 20-pole stator (Figs 1 and 2). The rotor, manufactured and tested so far, is measuring roughly 20 cm in diameter, and consists of 728 permanent cylindrical magnets affixed to an iron sphere. To maintain as much symmetry as possible, the number of regularly distributed poles on the rotor follows the distribution of the 8 vertices of a cube. The reaction sphere's rotor can be accelerated about any desired axis and moved in any direction continuously without any disruption using a 20-pole stator that produces an 8-pole rotating field.

The first rotor CSEM developed was not simulated; it was designed just using a pure analytical model of the electromagnetic field. This meant that the size

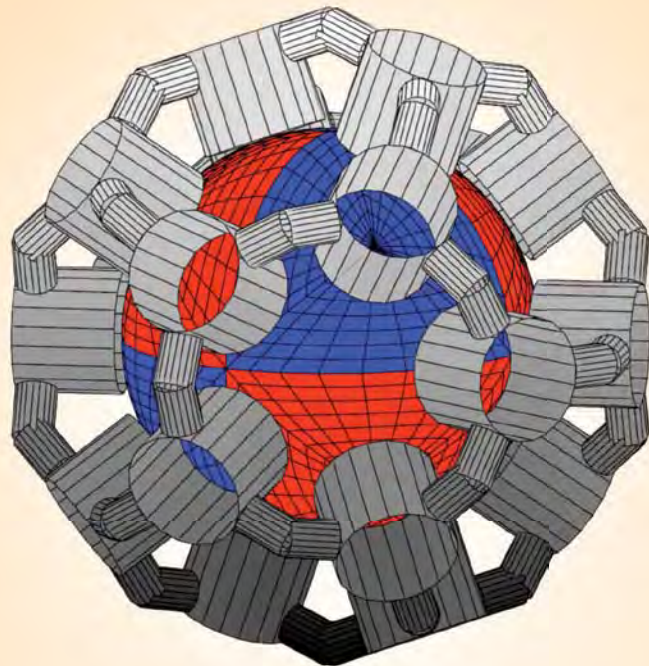

Fig. 1. Geometry of the 3D motor on a magnetic bearing for the reaction sphere; in the ideal case 8 permanent magnets for the rotor (whose fields today we approximate instead using a mosaic of 728 cylindrical magnets) and 20 coils for the stator.

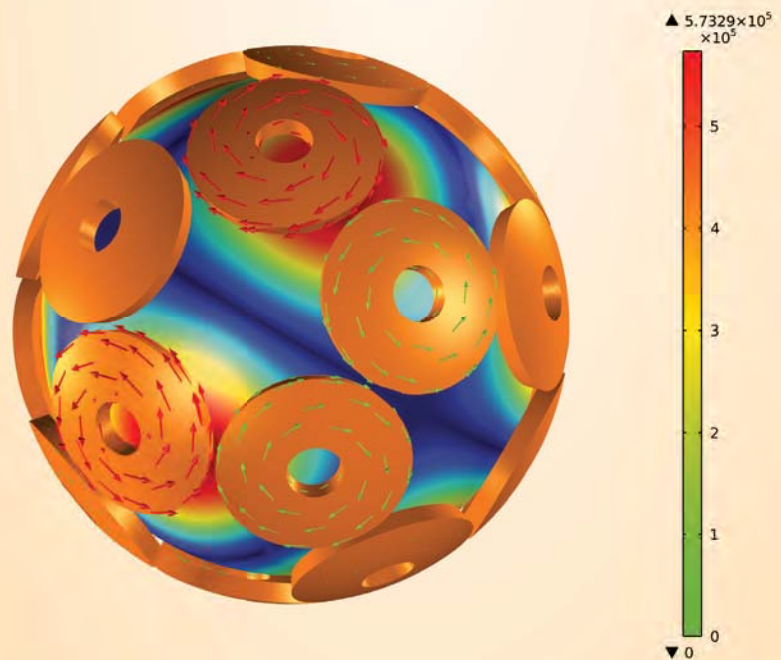

Fig. 2. Model geometry showing the coil distribution around the rotor.





Surface: Magnetic scalar potential (A) Arrow: Magnetic flux density

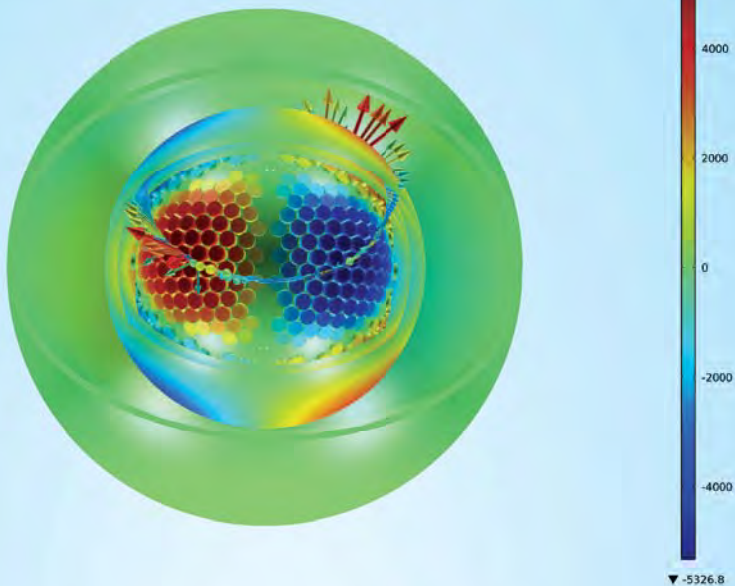

Fig. 3. Radial magnetic flux density at the rotor surface (surface plot) and magnetic flux density (arrow plot).

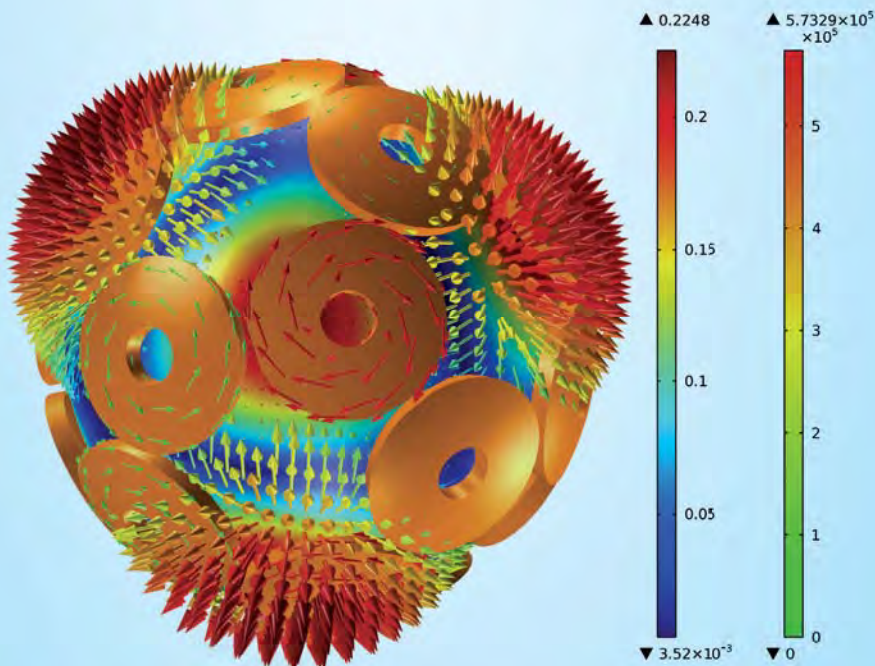

Fig. 4. Taking Fig. 3 and adding the effects of the energized coils adds the current density in the coils (additional arrow plots).

of the magnets had to be adjusted using this analytical model. But in order to synthesize these cylindrical magnets the team had to make several assumptions, which relied on intuition.

Now, with COMSOL, what's powerful is that we take the insight derived from a good initial guess of the analytical model and then run the software to finely tune the design to meet some optimization criteria. We are, however, considering some special designs where the magnets have geometries and very particular magnetization patterns, for which the development of an analytical model would be extremely difficult.

Instead, with software we now can evaluate multiple designs where we vary the reaction sphere's mass, torque and magnetic fields, and we can also investigate unusual geometries for the magnets or create the magnetic field from the coils in different ways. Thanks to COMSOL we can take an intuitive idea, build the geometry, run the simulation and within several hours can evaluate whether a given design should be further investigated. In summary, there are certain designs we are currently evaluating that we would have not been able to test using analytical approaches — but with COMSOL it takes just a few hours.

We conduct our studies in two steps. First we determine if the magnetic field from the permanent magnets on the sphere provide the required flux fields (Fig. 3). In a second step we then simulate the coils being energized and verify the expected forces (Fig. 4) and then compare them to forces seen in a test bench (Fig. 5). The model has proven to be a powerful predictor for the forces because the computed values are in good agreement with the measurements. In a later step we want to add thermal analysis to find out what happens to the stator when the sphere is rotating and also add the LiveLink™ for MATLAB® module so we can design the controller electronics.

Our simulations with current were set up with the rotor orientation matching that on the test bench (Fig. 5). The vertical force is computed by integrating the Lorentz force on each of the twenty coils and summing them to obtain the net force.





## Remove the Iron

The ultimate goal is to obtain a specific magnetic flux density within the air gap while minimizing rotor mass and maintaining a level of useful inertia. Using COMSOL, we plan to study a different approach taking advantage of an interesting phenomenon. Like electrical circuits, magnetic circuits must be closed. In our current design, the metal of the rotor holding the magnets serves as the return path, similar to the ground in an electric circuit. However, in what is known as one-sided flux, a special arrangement of magnets can augment the magnetic field on one side while cancelling the field to near zero on the other side.

“The COMSOL model proved to be a powerful predictor for the forces, and this will be an invaluable tool for us as we study further design options.”

By taking advantage of this effect, we can possibly replace the rotor's iron core with a lighter weight material. In this new design, there's no need for iron to close the magnetic flux circuit inside the rotor because the flux is directed outwards by the magnetized material. Although the magnets and iron have roughly the same amount of mass, for the same volume/mass, replacing the iron with permanent magnets would increase the magnetic field outside the rotor — and allow us to reduce the current in the coils to operate the motor and thus cut power consumption. Here, again, COMSOL will allow us to immediately predict the performance of a particular design in terms of developed forces/torques and power consumption. ■

### LEARN MORE

[www.comsol.com/papers/9385/](http://www.comsol.com/papers/9385/)



Fig. 5. Test bench for the reaction sphere.

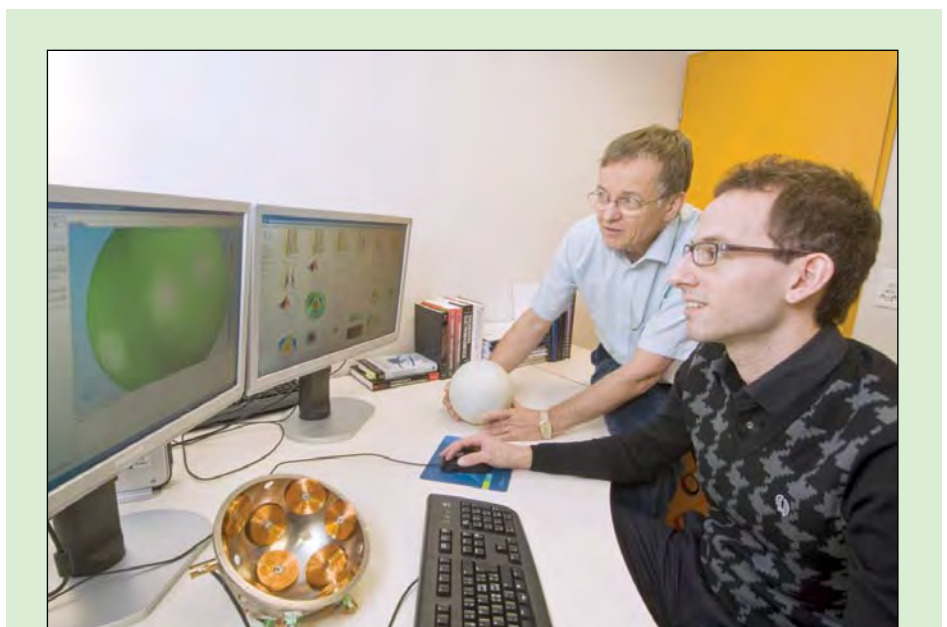

## About the Author

Leopoldo Rossini (on the right, sitting next to Senior Project Manager Ivar Kjelberg) received his BSc. degree in Electrical Engineering from the University of Applied Sciences of Southern Switzerland, Manno, Switzerland, and his MSc. in Electrical and Computer Engineering from Purdue University, West Lafayette, IN, United States. Since then, he has been employed in the Systems Division of the Swiss Center for Electronics and Microtechnology (CSEM) in Neuchâtel, Switzerland, and he is also currently a PhD student at EPFL (Lausanne) working on the reaction sphere project.



Using demand-controlled ventilation at large facilities such as CEA-MINATEC can help significantly cut energy costs.



## Optimization Slashes Energy Consumption in Silicon-Based MEMS CO<sub>2</sub> Detectors

Demand-controlled ventilation, where incoming air is brought into buildings based on actual occupancy, relies heavily on CO<sub>2</sub> sensors. Modeling is helping to make them smaller and less expensive.

BY SERGE GIDON, CEA, LETI, MINATEC, GRENOBLE, FRANCE

Adequate ventilation with outdoor air is essential for occupants living or working in buildings. In fact, building codes require that a minimum amount of fresh air be provided to ensure adequate air quality because inadequate fresh air can have detrimental effects on building occupants and reduce their productivity. To comply with regulations that require certain levels of fresh air, ventilation systems have traditionally drawn in air at a fixed rate based on an assumed occupan-

levels and air quality so that the ventilation system draws in only the amount of fresh air actually needed. Studies have found that such methods can often drop energy consumption associated with ventilation by more than half compared to a fixed rate of air intake.

### Low-Cost CO<sub>2</sub> Sensors

One key to the widespread use of this technology is low-cost CO<sub>2</sub> sensors. One group working on this task is the Optics

very low current so that it can be left in a building for many years without the need to replace batteries. Such a sensor typically takes a reading five to ten times per hour, and a measurement requires only approximately 100  $\mu$ J of energy.

In addition, they should cost considerably less than conventional CO<sub>2</sub> sensors in use today, which generally sell for several hundred dollars each, and allow the widespread adoption of this technology.

The overall sensor functions in this way: first, a filament is heated to a specific temperature (650 °C) so it emits most of its infrared radiation near a specific wavelength, 4.2  $\mu$ m. The ambient CO<sub>2</sub> absorbs much of this energy, and the remaining infrared radiation is detected to allow calculation of the amount of CO<sub>2</sub>.

**“The current focus of our research based on COMSOL Multiphysics is finding the optimum geometry for an energy-efficient filament.”**

### The Optimum Geometry

The current focus of our research based on COMSOL Multiphysics is finding the optimum geometry for an energy-efficient filament. This element is the sensor’s primary energy consumer and our goal was to optimize its design to consume as little power as possible. We are optimizing the design of the filament to avoid hot spots on the freestanding micro hotplate that

cy, and generally more fresh air enters buildings than is necessary. This results in higher energy consumption and costs because the incoming air must be heated in the winter and cooled in the summer.

In the last decade, there has been a strong trend towards DCV (demand-controlled ventilation) systems based on CO<sub>2</sub> sensors. These monitor actual occupancy

Department of CEA-MINATEC, an international center for micro and nanotechnologies with 2400 researchers; it is part of CEA, a French government-funded technological research organization. There researchers are working with an industrial partner to develop silicon-based MEMS CO<sub>2</sub> sensors that use optical detection. Such a sensor will run at

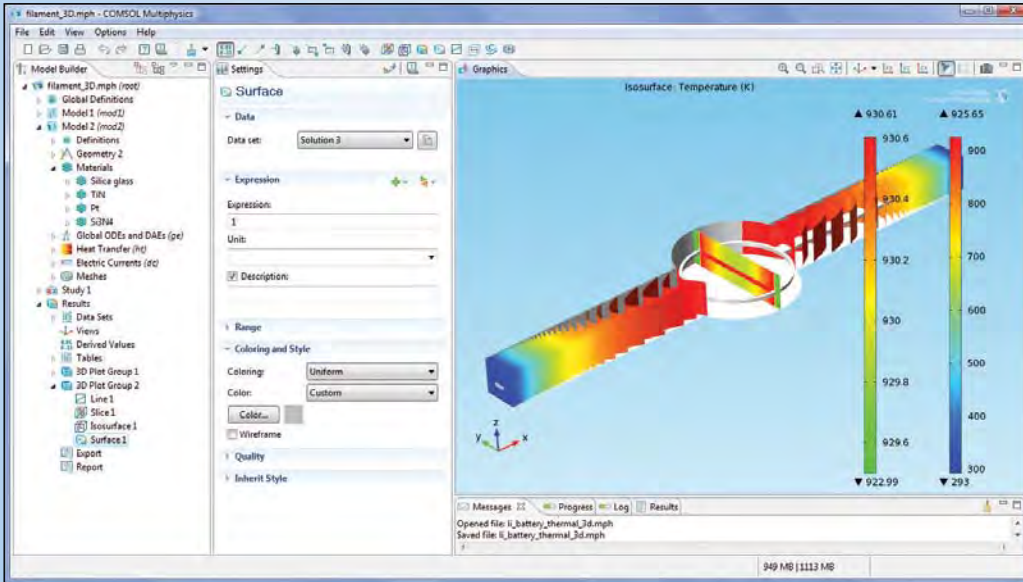

Figure 1. The image shows the temperature distribution throughout the sensor; temperature in the conductive tracks is visualized with isosurfaces (right colorbar), temperature in the filament is visualized using a sliceplot through the center of the filament (left colorbar).

is made of  $\text{Si}_3\text{N}_4/\text{SiO}_2$  layers supporting TiN/Pt/TiN tracks.

In the sensor, the filament serving as the thermal source is located in a disc roughly 100 microns in diameter (Fig. 1). When raised to  $650^\circ\text{C}$ , it emits most of its radiation near the desired wavelength of  $4.2\ \mu\text{m}$ . Because the wavelength is very sensitive to temperature, homogeneity of temperature across the entire filament is crucial. If we overheat the filament at some position, energy is wasted and the device could suffer failure in hot spots. If there are points in

the filament with a temperature that is too low, it won't get energy at the required  $4.2\ \mu\text{m}$ . As for the width and relative locations of the three circular filaments' tracks, it is important to optimize these aspects. For instance, if a track is too thin, this radiative element won't emit at the right temperature.

The width of the arms is also important because the resistivity and thus current flow varies with the geometry. They must be wide enough to avoid Joule heating (which is desirable in the conductive tracks but not here), but they cannot be

too wide or else the thermal resistivity drops and excess heat flows away.

### 2D Works Just as Well as 3D

For our studies, we initially created a 3D model, but for the optimization we chose to use a 2D simplification that is easier to set up and requires less computing resources (Fig. 2). In the 2D model we introduced an equivalent conductivity of the layers that doesn't account for thermal diffusion processes arising in the upper layer of the actual structure and it thus exaggerates the influence of the heating tracks. Even

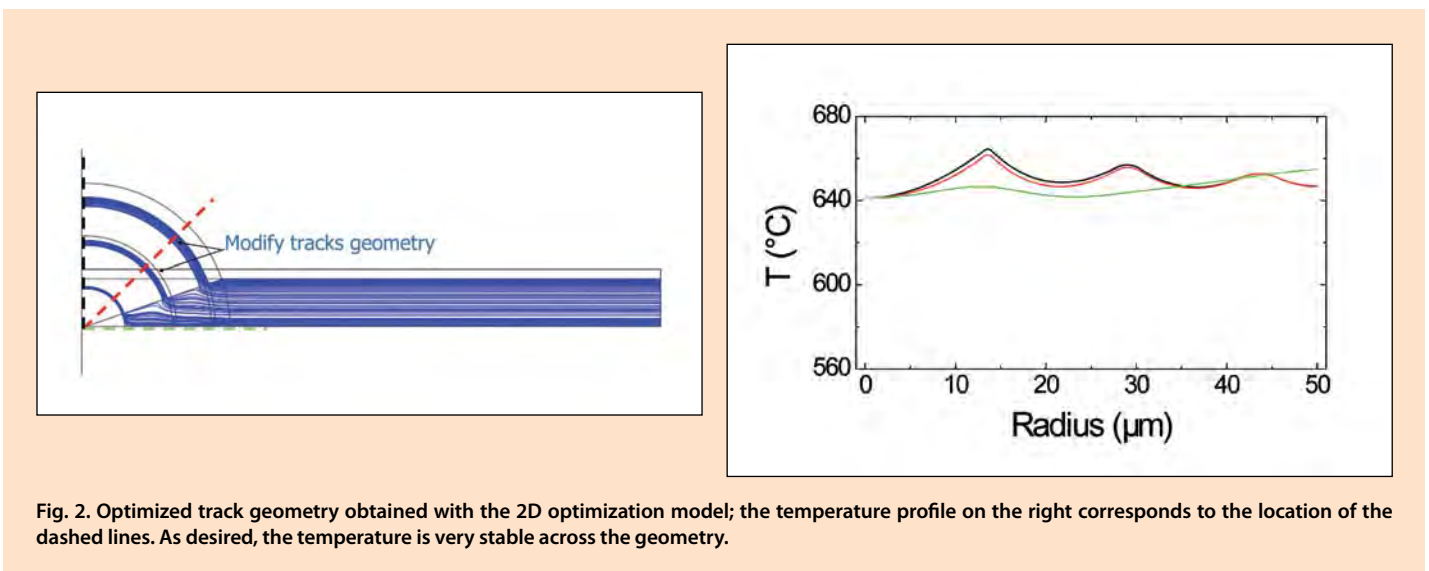

Fig. 2. Optimized track geometry obtained with the 2D optimization model; the temperature profile on the right corresponds to the location of the dashed lines. As desired, the temperature is very stable across the geometry.

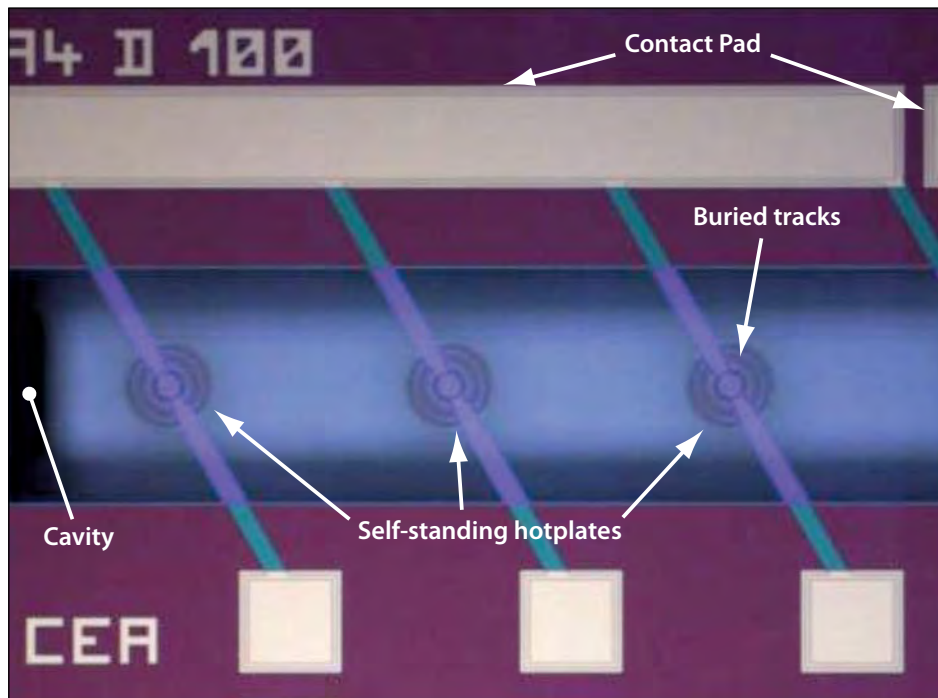

Figure 3: Photograph of the actual sensor. (Photo courtesy of CEA-MINATEC)

so, we found that the simplified approach provides a temperature profile comparable to the 3D model; when we plotted temperature for the desired point in the geometry for both cases, the value was essentially the same. This gave us the confidence to continue with the optimization using the 2D geometry.

Next we moved on to the optimization process itself. Here we had a number of parameters to work with: the positions of the three circular tracks, the widths of the two outer tracks (the inner track's width is imposed by lithography as well as process and performance requirements), and the thickness of the conductive tracks on both sides which determines their resistance and thus the proper voltage to apply.

To run this optimization, we turned to COMSOL's ALE (Arbitrary Lagrangian-Eulerian) method, which is an intermediate between the Lagrangian method (where the coordinate system follows the material as it deforms) and the Eulerian method (where the coordinate axes are fixed in space). ALE combines the best features of the two methods upon which it is based: it allows moving boundaries without the need for the mesh movement to follow the material. We found that through the optimization process and with proto-

types (Fig. 3) that the temperature dispersion along the filaments has dropped from  $\pm 20$  °C to  $\pm 10$  °C; further, we have been able to cut energy consumption by at least a factor of two. Further, I have come to appreciate COMSOL's ability to allow engineers to perform applied physics, and thus I expect that the software will soon

integrate geometric optimization without the need for the ALE method.

### Moving Towards Commercialization

We are working with an industrial partner to commercialize this sensor technology, but we don't expect it to reach the market for a year or more. It depends on the success of many other sensor elements; for instance, the filter for detecting only the desired radiation is a key point. Here, too, we can use COMSOL to help us gain better understanding of the problems and how to solve them.

Choosing COMSOL for this study was an obvious choice for me. I've been a long-time user having started with very early versions, and I've used it enthusiastically for many projects. I'm doing physics not computations. I appreciate COMSOL's ability to test my vision and not the ability of my PC to do something. Among some recent projects were to model double-gate MOSFETs and to examine emerging techniques for increasing the capacity of optical storage devices. More than 50 people at MINATEC are involved in simulation, and plenty of them are turning to COMSOL. ■

### LEARN MORE

[www.comsol.com/papers/7780/](http://www.comsol.com/papers/7780/)

## About the Author

Serge Gidon is a research physicist at the Optonics Department of MINATEC, which is an applied research laboratory of the French Atomic and Alternative Energy Commission (CEA) that is devoted to the development of micro- and nanotechnologies. He received an undergraduate degree in electro-technical engineering at the National College of Grenoble and a post-graduate diploma in optical instrumentation at the University of Grenoble. After 12 years working on large optical facilities at CEA, he joined LETI (one of the MINATEC labs) and for the last 16 years has participated in projects involving optical microsystems, micro lasers, bolometer images, data-storage discs and more recently optical sensors such as gas detectors.



Research Physicist Serge Gidon.

# COMSOL CONFERENCE WORLDWIDE 2011

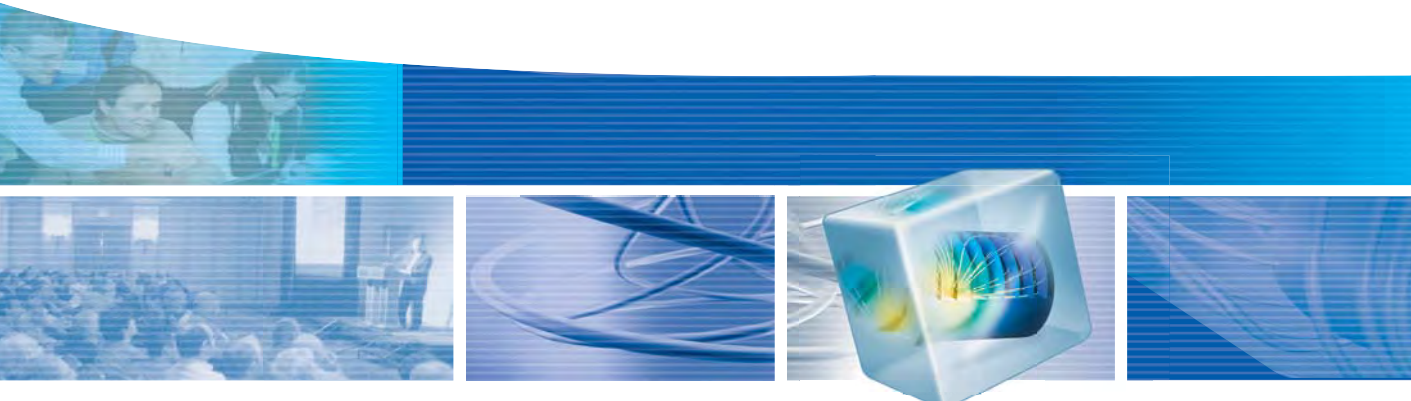
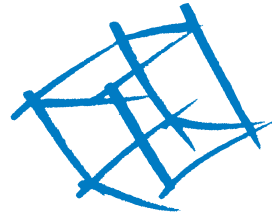

## Join us for the COMSOL Conference 2011 The premier event for multiphysics simulation

- Discover new multiphysics modeling strategies
- Connect with key industrial and academic contacts
- Sharpen your simulation skills in minicourses
- Showcase your own modeling projects

DATE & LOCATION **Boston**, October 13-15  
**Stuttgart**, October 26-28  
**Bangalore**, November 4-5

Sign up today!  
[www.comsol.com/conference](http://www.comsol.com/conference)



Boston • Bangalore • Stuttgart



© 2011 COMSOL. COMSOL and COMSOL Multiphysics are registered trademarks of COMSOL AB. Other product or brand names are trademarks or registered trademarks of their respective holders.



# Restoration of Lake Water Environments

The injection of oxygen microbubbles help reduce toxic substances by reinforcing nature's original self-restorative capacity.

BY SHUYA YOSHIOKA, RITSUMEIKAN UNIVERSITY, JAPAN

**B**y increasing the number of lakes that can be used as a source of water, we can reduce the need to develop new water resources and avoid major environmental impact. However, in recent years, human activity has been steadily robbing such enclosed areas of their oxygen, and this oxygen-deficient water typically contains high levels of toxic substances such as metals and organic material. One approach to water treatment is to inject oxygen microbubbles. This dissolved gas oxidizes the metals and causes them to precipitate; the oxygen also stimulates the activity of microorganisms that break down and remove organic material. Determining the most effective and cost-efficient way to inject microbubbles was the subject of research where we found COMSOL Multiphysics made a key contribution.

## Oxygen: An Inexpensive Cleaning Agent

Water "purification" means eliminating pollutants or transferring them away from the area concerned, and this has typically been done in water-treatment plants. While it's desirable to clean the water, it's also important to consider the pros and cons for the environment: if the required energy is derived from fossil fuels, the process might do more harm than good.



Figure 1. Field experiments at the Sounoseki Dam.

Thus, we use oxygen, and if pollutants enter the water as a result of a natural disaster or climatic change, they can be quickly eliminated thanks to the water's high oxygen content. This is nature's original self-restorative capacity.

With the cooperation of the administrative agencies of Miyagi Prefecture, we are conducting field experiments at the Sounoseki Dam (Fig. 1). Our approach to the restoration of the water environment here involves the use of micrometer-sized microbubbles. A very large number of microbubbles results in a greater air-liquid interface area for the same volume of gas. Moreover, the smaller the bubble, the greater its internal pressure. These characteristics can be used to promote efficient dissolution of the gas held in the bubbles into the water. Furthermore, because the buoyancy force acting on microbubbles is small, they rise to the surface very slowly and can remain in the water for several minutes or even hours, allowing the dissolution of the gas to continue. In our experiments we create microbubbles through the high-speed mechanical agitation of water to which a gas is added (Fig. 2).

Reservoirs and dams may contain anywhere from several hundred thousand to several million cubic meters of water. Oxygenating this much water requires a huge quantity of microbubbles. Even so, this does not mean that huge amounts of energy are required. For instance, in the validation field experiments we are conducting at the Sounoseki Dam, only 2 - 5 liters/minute of air are required for a lake containing a million cubic meters of water. We



Fig. 2. Microbubble generator on the site.

have been able to confirm that this rate of oxygenation has improved water quality with a sharp fall in the levels of toxic substances such as nitrogen, phosphorus, iron and manganese.

## Multiphysics in the Water

In these trials, it is necessary to predict all the environmental phenomena that might affect the body of water (wind, water flow, temperature, chemical reactions, and diffusion). In particular, we must consider the way in which winds raise waves on the water surface; these, in turn, create currents. We then study how these currents stir up the sediment and alter water quality. The equations that govern these phenomena must all be solved simultaneously. In other words, this is a typical multiphysics problem. To deal with them, we have been using COMSOL's powerful multiphysics analysis technology as well as the CFD and Chemical Reaction Engineering modules.

This software has helped us to decide where, and at what depth and at what speed to introduce the microbubbles. As shown in Figure 3, a natural wind blowing from left to right raises waves on the surface of the water and creates currents that mix the bottom sediments. The sim-



ulated water currents in the Sounoseki Dam have revealed the existence of a large-scale recirculation region, and we utilize this current for the efficient diffusion of microbubbles throughout the entire dam (see Figures 4 and 5).

On the basis of the studies using COMSOL Multiphysics, we are currently conducting validation experiments of the oxygenation process involving large-scale test apparatus in collaboration with Institute of Ecological Engineering. Through oxygenation for a period of approximately 1 month while the reservoir was at maximum capacity (1 million cubic meters), we were highly successful in eliminating toxic substances (Fig. 6).

We intend to conduct further field experiments of this environmental restoration process in various locations with a view to the development of practical applications of the technology. These are large-scale and complex experiments, but with the support of COMSOL Multiphysics, we will continue to pursue our work. ■



### About the Author

Dr. Shuya Yoshioka is Associate Professor in the Department of Mechanical Engineering, College of Science and Engineering, at Ritsumeikan University in Japan. He completed his doctorate at Keio University, and his main areas of research include the formation of nano-micro bubbles and their application, the development of efficient wind turbine system, and the control of unsteady turbulent flow.

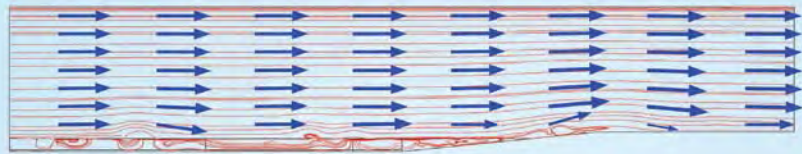

Fig. 3. Results of COMSOL Multiphysics numerical analysis of flow field within a cross-section of the reservoir bank (air at top, water at bottom, sand bank to right).

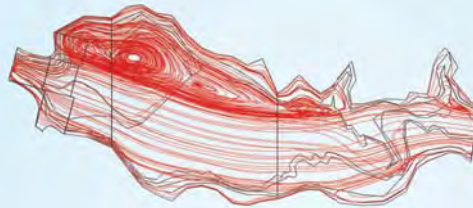

Fig. 4. Results of a simulation of currents within the Sounoseki Dam reservoir.

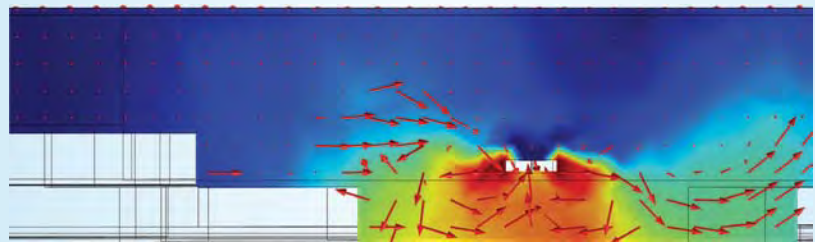

Fig. 5. Results of a simulation of mass (simulating microbubbles) diffusion over a cross-section of the Sounoseki Dam reservoir.

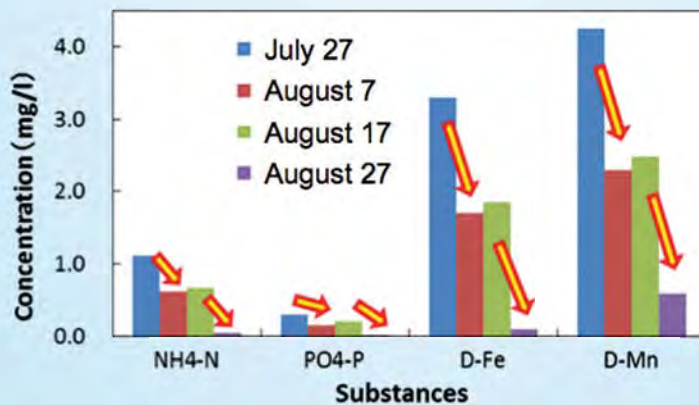

Fig. 6. The results of the trials show a reduction in the concentrations of various toxic substances (the experiment was suspended from August 7 to 17).



## Making the Oil Supply Safer and More Stable

When the supports or risers from oil platforms go down hundreds of meters, they experience tremendous stress due to the motion tides and waves. Rather than send divers down to check welds, operators can use a new technique called ACFM (alternating current field measurements) that has been refined with the help of COMSOL Multiphysics.

BY FILIP VAN DEN ABELE AND PATRICK GOES, OCAS N.V.

**E**recting offshore oil platforms is very expensive, with costs often exceeding half a billion dollars, and so there's a strong emphasis on the engineering effort needed to make sure they not only are safer for operators, but have a reasonable useful service lifetime as well. Such semi-submersible platforms often use spars made of welded sections that descend into the sea for stability and then use welded risers to bring the oil and gas to the surface. Modeling software is helping engineers find mitigation measures that extend the lifetime of such structures as well as refine non-destructive test methods that can detect and monitor the development of cracks in welds, even at ocean depths far below what divers can reach.

### Every Weld has a Defect

Problems begin with the fact that the risers are made of tubular sections that are welded into a single piece. Next, it's important to realize that no weld is perfect; even in a virgin pipe or riser there will always be some defects. These include internal cracks (which are sharp and thus detrimental to fatigue resistance), lack of fusion, voids and porosity. In addition, a weld's geometry gives rise

to stress concentrations, again reducing the fatigue life.

Then add the fact that it's not just storms that are put enormous loads on these welds; even moderate sea currents can create oscillations, which lead to cyclic loading whereby even tiny inherent defects start to grow, making them vulnerable to fatigue failure over time. Detecting welds that are developing dangerous fatigue cracking is crucial so that mitigation measures can be taken to strengthen these weak spots or to determine that it's time to decommission a drilling platform.

This is a large part of our work at OCAS, which is a market-oriented research center providing innovative solutions and services to metal-processing companies worldwide. Located in Belgium, it's a joint-venture of the Flemish Region and ArcelorMittal. Of our 140 employees, roughly 15% are involved in simulation using a wide variety of codes including some dedicated tools for sheet metal forming and deepdrawing processes. However, for more exotic topics, in particular projects involving electromagnetics, fluid-structure interaction, welding processes that involve multiphysics couplings and heat transfer analysis, we turn to COMSOL Multiphysics.

### Crack Detection at Great Depths

A major issue for VIV is examining the failure mode given that fatigue damage in girth welds is inevitable. The challenge is performing crack detection in underwater welds. Visual inspections looking for early cracks aren't practical, especially since divers are limited to only several hundred meters. Over the years a number of alternate methods for non-destructive testing have been developed, but one very interesting emerging technology is ACFM (alternating current field measurements).

In ACFM, the test engineer injects a uniform incident current in a weld, thus inducing an Eddy current or Foucault current in the conductive material. The Eddy currents induce a magnetic field which is opposed to the magnetic field of a sensor coil. The presence of flaws causes a change in the Eddy currents; Two sensor coils measure the fields which are parallel and normal to the crack. The presence of a surface discontinuity diverts current away from the deepest part and concentrates it near the ends of the defect. As a result, one magnetic field contains information about the defect's depth and the other measures the crack's length.



This method is superior because, in contrast to others, it provides information on crack shape and sizing as well as position. If you can detect a crack and its size, you can monitor its growth over time, leading to an accurate prediction of a structure's useful lifetime. In addition, the ACFM method is able to detect cracks through several millimeters of non-conductive coating, allowing inspections through paint, epoxy, oxide layers, fire-protection coatings and even marine growth.

Interpreting the information in the measured magnetic fields is where COMSOL comes into play. Using the AC/DC Module, we simulate the ACFM technique and study the effect of crack size on the measured magnetic components. In the geometry, a cylindrical air box confines the model boundaries and the crack consists of an ellipsoid. The magnetic field interface is used to model a current-carrying wire and to inject an almost uniform current distribution into the thin steel plate.

With this model, we were able to gain a good understanding of the underlying principles and arrive at some formulas and guidelines. In ACFM, at the spot where the measurements are taken, the tangential magnetic field component  $B_x$  contains information about the depth of a possible crack, and the normal magnetic field component  $B_z$  reveals its length.

The corresponding signals  $B_x$  (tangential magnetic field) and  $B_z$  (normal magnetic field) are shown on Fig. 1. The uniform input current is disturbed by the presence of a surface-breaking defect, and the lines of current are forced to flow around the ends of the crack. The  $B_x$  signal shows a peak where the lines of current are closely concentrated and a trough where they are sparsely distributed. A clockwise flow is translated into a positive  $B_z$  peak, and the counterclockwise flow is reflected in the negative  $B_z$  signal.

More complex ACFM probes are available containing multiple inspection sensors. These are known as ACFM arrays and allow larger areas to be inspected in a single scan. These can also be fitted with position encoding to allow a complete record of the distance traveled and the exact location of defects found. Examples of such systems developed for the oil industry are

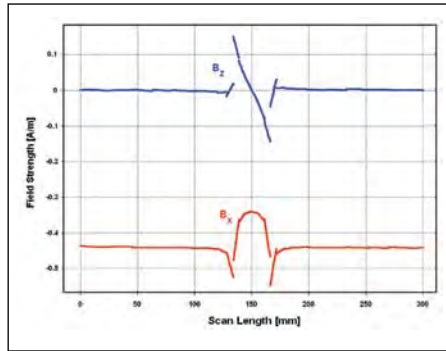

Fig. 1. Magnetic field components resulting from an ACFM measurement.

an automated system for the inspection of titanium drilling risers developed for Statoil in Norway.

### Saving Lives, Time and Money

Inspections of undersea risers using conventional methods normally include the cost of installing access platforms, paint removal, the inspection itself, repainting and finally removing the temporary access. Depending on the application, in some cases it's even necessary to shut down the plant to reduce temperatures before the inspection can take place. If coating removal and the construction of access platforms can be avoided, very significant cost savings are possible, not only in direct

costs but also by reducing the duration of interruption. Time and cost savings up to 60% have been reported in some industries by the introduction of the ACFM technique. For the past three years, ACFM has been used by PETROBRAS for the inspection of selected structural welds on a fixed and floating (semi submersible) platform located in the Campos Basin. Excellent results have been achieved and the estimated saving compared to conventional inspection methods employing magnetic particle inspection (MPI) is \$1,500,000.

Of course, this new technique has benefits beyond just saving money. It's obviously important that quality not be compromised. Trials of the technique have been compared with MPI and show good performance, leading to its acceptance by major certification authorities around the world including DNV (Det Norske Veritas), ABS (American Bureau of Shipping), the Bureau Veritas Group and OCB Germanischer Lloyd. As all data is stored, irrespective of whether or not a default is found, the results are available for audit or review by an independent expert without the need to revisit the site. ■

### LEARN MORE

[www.comsol.com/papers/7209/](http://www.comsol.com/papers/7209/)

## About the Authors

Filip Van den Abeele holds an MS in Mechanical Engineering and a PhD in Engineering Sciences from the Soete Lab at Ghent University, Belgium. He has recently completed his MS in Ocean and Offshore Technology at Cranfield University, UK. Filip is working as a simulation expert at OCAS N.V., a joint venture between ArcelorMittal and the Flemish Region. His main research focus is on offshore pipeline design and vortex induced vibrations, and he is actively promoting the use of multiphysics modeling for the oil and gas industry.



Dr. Filip Van den Abeele (left) discussing his findings with a colleague.

Patrick Goes studied physics and philosophy at Ghent University and holds a MS in both disciplines. From 1985 on he has been involved in software development, mathematical modelling, and the development of electron beam texturing technology (EBT) at ArcelorMittal Gent. In 2005 he joined OCAS N.V. as senior research engineer, responsible for modelling and simulation, multiphysics finite element analysis and fatigue analysis.

# Analysis and Simulation of Rock Properties

BY EDWARD BROWN, TECH BRIEFS MEDIA GROUP

Unearthing the hidden structure of rocks — that's what Shuang Zhang and his colleagues achieved by using the combination of VSG's Avizo 3D Analysis software and COMSOL's Multiphysics modeling and simulation software<sup>1</sup>.

Since American oil and gas reserves are becoming increasingly more difficult to access, the industry has been turning to the technique of injecting fluid under pressure into rock deposits in order to harvest oil and gas that is trapped inside. This process requires knowledge of the structure of the shale formations in an oil field site. The process relies on being able to predict the ability of fluids to penetrate the rock. "There are two important physical parameters in order to determine this," said Dr. Zhang, "these are porosity and permeability." Porosity is a measure of how much void space exists in the rock and permeability characterizes how well the fluid will flow through it. "Of course, these two parameters are strongly correlated," he continued. "The work of discovering these parameters has generally been done by obtaining a rock sample and examining it in a physical laboratory," said Dr. Zhang.

Dr. Zhang, along with his VSG colleagues and customers demonstrated an innovative method for doing this analysis without using physical laboratory techniques. They took a brick-shaped

shale sample (Figure 1a) and deconstructed it by using a focused ion beam-scanning electron microscopy (FIB-SEM) system (Figure 1b) to obtain data at a nanoscale level from the sample (Figure 1c). The Avizo software uses this data to construct a digitized three-dimensional model representing the pore distribution within the sample. "The value of the COMSOL software for our project is its ability to use the geometry representing the pore network of the rock to perform a flow simulation. This flow simulation is very important for determining how permeable the rock," said Dr. Zhang.

## FIB-SEM

The FIB-SEM technique uses an ion beam to mill away a layer of the rock sample. Detailed digital data of the structure of the exposed layer is obtained by the scanning electron beam microscope at a resolution down to a few nanometers. By repeating this process over and over, a 3D volume is assembled from the stack of fine-scale images of each layer. After preprocessing to eliminate effects such as misalignment between layers and random noise, the Avizo software is used in an interactive fashion to create a digitized mathematical model of the shale sample. This process is actually quite similar to the way images of the human body are constructed by using

tomography techniques as in CAT scans, PET scans and MRIs.

The shale is composed of three types of material: mineral matter, organic matter and void-spaces. These are termed phases and their significance is that the rock is made up of a complex nanoscale arrangement of these phases, which is what ultimately determines the flow characteristics. If the voids are of microscopic size and distribution, FIB-SEM scanning can generate data that would be impossible to find in a physical lab.

## Three-Dimensional Model Reconstruction

Once the data for the 3D model has been assembled and stored, the Avizo software creates the geometry model and the corresponding volumetric mesh structure. This model can create a display of the three phases rendered with different shadings. A critical feature is the ability to extract a small region of interest (ROI), which will reduce the amount of computation data storage resources needed to a manageable level.

In performing the analysis, data regarding the three phases is separated out (segmented) and quantified, so that the percentages of the total volume for each phase can be calculated. This separation step is called image space segmentation. A further step, called pore

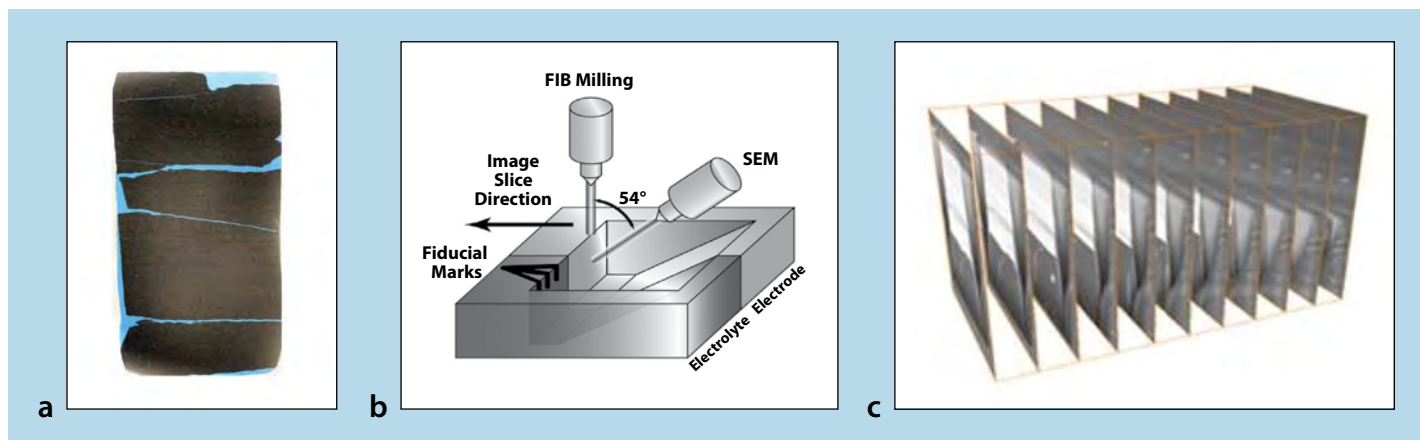

Figure 1. (a). Shale rock sample; (b). Schematics of FIB-SEM dual column setup; (c). Example image stacks acquired with FIB-SEM.

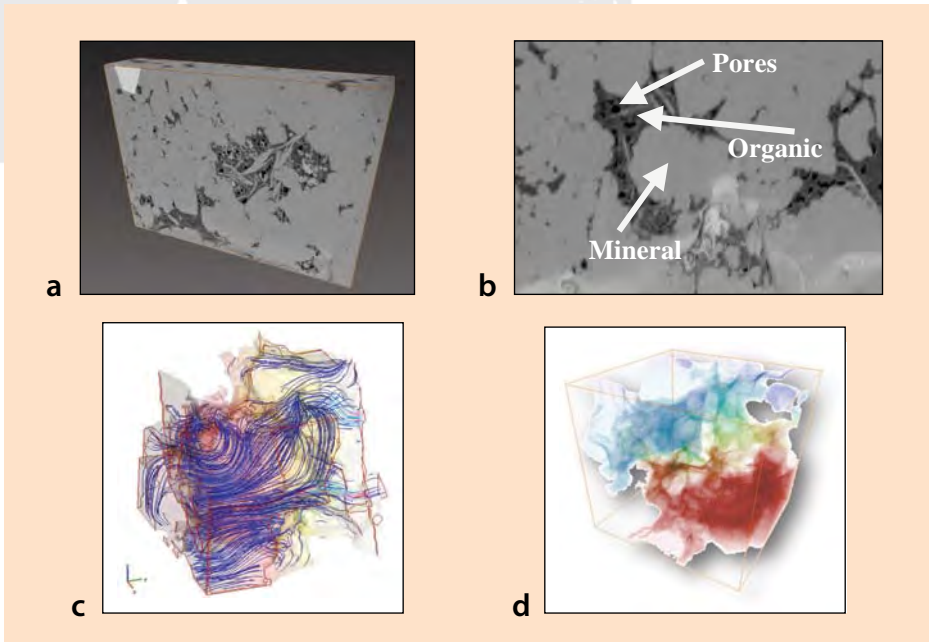

Figure 2. 3D Reconstruction of one FIB-SEM imaging data, with 3072x2304x355 spatial resolution and anisotropic voxel size of 2.8x2.8x5nm<sup>3</sup>. (a). Hardware accelerated volume rendering with out-of-core technology; (b). Identification of different phases; (c). Streamline visualization on COMSOL simulation results; (d). Volume visualization of pressure distribution within the pore space using Avizo.

space segmentation, separates the pores into “dead pores,” “connected pores,” and “pore throats.” These steps enable detailed statistical analysis of the nature and distribution of the pores throughout the volume. It is this pore network that enables the COMSOL software to perform a simulated flow experiment.

“A significant benefit of being able to represent the sample in digitized form is that physics phenomena governed by mathematical models such as partial differential equations can be calculated,

using data representing real-world geometry, through the PDE solvers such as COMSOL,” said Dr. Zhang. Properties such as permeability, molecular diffusivity, heat conductivity and electrical resistivity can be determined in this way.

### Flow Simulation

The two important parameters for determining flow are porosity and permeability. Porosity is calculated with the Avizo software by using the 3D image it has created from the FIB-SEM data.

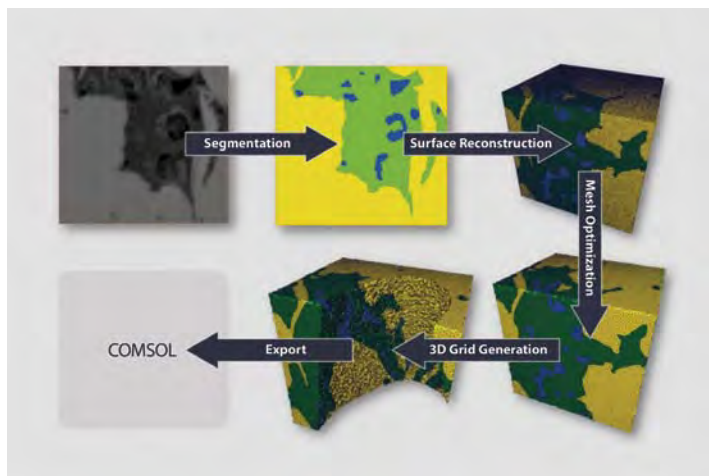

Figure 3: Rock property simulation with traditional geometry based approach.

Once the image-based digitized model has been constructed, the COMSOL Multiphysics software can be used to conduct a virtual physical experiment. In order to calculate the absolute permeability, it is necessary to obtain the average fluid velocity and the applied pressure.

“These values are obtained from the flow simulation, which is conducted by the COMSOL software.” said Dr. Zhang.

The COMSOL flow simulation sets up a velocity inlet on one side of the digital sample and a pressure outlet on the opposite face. The four other sides, as well as the pore boundaries are set up as non-slip walls. “Traditionally this type of analysis has to be done in a physical laboratory, where the process is expensive, inaccurate, incomplete, and time consuming,” said Dr. Zhang. COMSOL further outputs the results of this virtual physics experiment in a format that can be used by the Avizo software to create visualizations of the pressure distribution within the pore space, velocity vector plots, and a display of streamlines representing pressure.

### Advantages

Using FIB-SEM and VSG’s “Virtual Material Studio” enables a detailed and accurate analysis to be performed on a sample of shale from an oil field. Once the digitized data is input using the FIB-SEM technique, a tomographic analysis is used to create a mesh image of the sample. The computer does the rest of the work.

As Dr. Zhang put it, “COMSOL takes the geometry generated by Avizo and performs the flow simulation and Avizo takes the data generated by the simulation and uses it to create powerful visualizations.”

“When our simulation-based method is validated, we will be able to solve things that cannot be measured in a physical lab...We can do things in the digital world a lot cheaper and faster compared to a physical lab,” said Dr. Zhang. He went on to say: “Industry is just becoming aware of this image-to-simulation workflow (Figure 3). An extraordinary amount of information can be extracted from this workflow — much more than we have ever seen before.” ■

### REFERENCE

<sup>1</sup> S. Zhang, F.D. Maestra, N. Combaret, R. Klimentidis, P. Barthelemy, R. Albou, D. Lichau & D. Bernard. “The Analysis and Simulation of Rock Properties Using FIB-SEM and Virtual Material Studio”. NAFEMS World Congress 2011, Boston, USA, May 22-26, 2011.





Niklas Rom  
COMSOL Support

Here I collect inside tips and tricks for both the beginner and the seasoned COMSOL user. The idea is to show small but clever, and sometimes not very well-known features in the software. I rely on experiences from my daily work supporting customers, and pick tips that helped users in a neat way.

## Model Library Update

Periodically do View->Model library update. You will get tons of updated and brand new models added to your library. Also do Help ->Check for Updates to keep your software up-to-date.

## The Name Matters

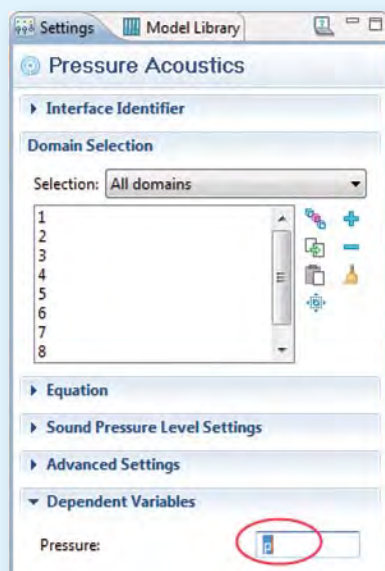

Did you know that you can change the name of your dependent variable on the fly? The variable name is important for a quick and intuitive feel of what it describes, say  $p$  for pressure,  $x$  for molar fraction. In the true multiphysics spirit, you will sometimes end up extending your model more and more, adding physics or even custom equations to an existing model. If you want to revise the variable names after a while, just click the physics interface and have a look at the bottom of the Settings view. Unfold the Dependent Variables section and change the name.

## Frequency Dependent Meshing

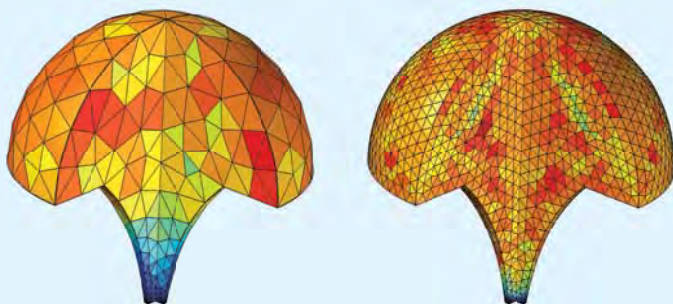

The accuracy in a model solving an equation for electromagnetic, structural, or any other kind of waves is often limited by how well the mesh resolves the waves. A good rule of thumb is to use at least 5 quadratic elements per wavelength in all directions. In cases where the highest frequencies in your model dictate a very fine mesh, you can save a bit of solution time by using a coarser mesh only for the lower frequencies. See the full description and examples at [www.comsol.com/support/knowledgebase/1103/](http://www.comsol.com/support/knowledgebase/1103/)

## Adding Auxiliary Equations

In COMSOL version 4.2 we made it easier to add additional algebraic and ordinary differential equations (ODEs). Here is an example: Recently, I was helping a user setting up a model of paper drying. We had a mass balance with convection and diffusion (Transport of Diluted Species physics interface) that took care of water vapor transport in the porous material. The vapor concentration variable was  $u$ . Now we needed to couple the evaporation rate to the moisture ratio  $W$ , which is the mass of liquid water held per kg dry solids. We had a mathematical model that related the moisture ratio  $W$  to the local vapor concentration  $u$  according to

$$\frac{dW}{dt} = -K(u_0 - u)$$

where  $K$  is a material dependent factor and  $u_0$  is a saturation vapor concentration. We knew the initial condition of  $W$  but had no transport equation for it, since the liquid phase was assumed to sit still in the porous material. Our task now was to get access to  $W$  as a field variable in the model because the physical properties we used depend on  $W$ . We thus had to solve the ordinary differential equation above to get  $W$ . So here is the shortcut:

1. Right-click **Model 1** in the model tree (or whichever model you work with) and select **Add Physics**. In the Wizard, Select **Mathematics->ODE and DAE Interfaces** and right-click **Domain ODEs and DAEs** and **Add selected**.

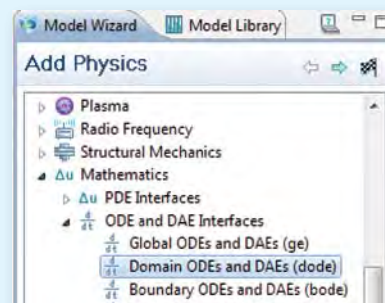

2. Click **Next** and **Time-dependent** and **Finish**.
3. In the model tree you will now find the node **Distributed ODEs and DAEs->Distributed ODE1**. If you click that node, you see the settings for the equation

$$e_a \frac{\partial^2 u}{\partial t^2} + d_a \frac{\partial u}{\partial t} = f$$

Now set  $d_a$  to 1 and  $f$  to  $-K*(u_0-u)$ . You will also need to set the initial value for  $W$  in the same setting. Learn more at [www.comsol.com/support/knowledgebase/913/](http://www.comsol.com/support/knowledgebase/913/)



## Hidden Command-Line Options

Several tasks can be programmed into the start command of COMSOL through command switches. In Windows, right-click the COMSOL shortcut and select **Properties**. Append `-h` to the **Target** line. An example target looks like:

```
C:\COMSOL42\bin\win64\comsol.exe -h
```

Click OK and then double-click the shortcut. Now, instead of the COMSOL Desktop, you will get an instruction screen explaining all the command switches to the comsol command. Here is an example:

[www.comsol.com/support/knowledgebase/1114](http://www.comsol.com/support/knowledgebase/1114)

## Oblique Incidence

Periodic boundary conditions are commonly used when the solution is identical but (prior to the simulation) unknown on two opposing boundaries. This is when the Floquet Periodicity condition comes in handy. Floquet conditions apply if you have an electromagnetic wave incident at an oblique angle on a material interface or a periodic structure. The phase shift is then given by the angle of incidence.

The Plasmonic Wire Grating example model shows how you can use Floquet conditions together with Ports to simulate a wire grating. The wave undergoes deflection, reflection and diffraction. The model is available in the COMSOL version 4.2 Model Library. [www.comsol.com/support/knowledgebase/1115](http://www.comsol.com/support/knowledgebase/1115)

## Skin Depth — To Resolve or Not to Resolve

If you expose a metal to a time-harmonic electromagnetic field, the field inside the metal will decrease exponentially with the distance from the surface. The skin depth is the depth at which it has decreased by a factor  $e$  (natural logarithm base). For a good conductor it follows the formula

$$\delta = \sqrt{\frac{2}{\omega\mu\sigma}}$$

where  $\omega$  is the angular frequency,  $\mu$  the permeability, and  $\sigma$  the conductivity of the material. For example, at 50 Hz, the skin depth in copper ( $\mu_r = 1$ ,  $\sigma = 6 \cdot 10^7$  S/m) is around 9 mm and in iron ( $\mu_r = 4000$ ,  $\sigma = 1.12 \cdot 10^7$  S/m) it is 0.34 mm.

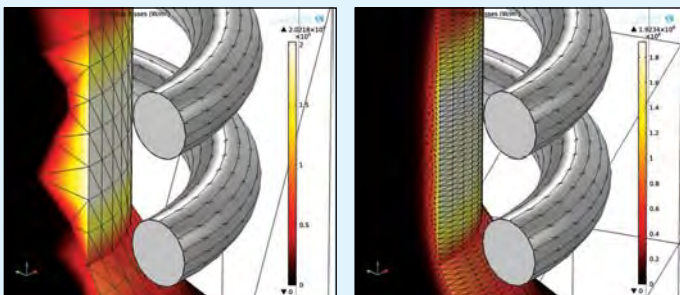

Resistive losses in an induction heating model. The color (from deep red to white) depicts the resistive heating. The left model is poorly resolved and the right well resolved. Both have identical input data. As skin depth decreases, consider using an impedance boundary condition instead.

If you want to accurately resolve the field gradients and the resulting induced currents in the metal, the size of each mesh element needs to be less than the skin depth, preferably by a factor of two or more. Depending on the material properties, the frequency, and the geometric dimensions in the model, resolving the skin depth can be anything from trivial to very challenging. Here's a way to solve this: if the skin depth is so small that you cannot afford to mesh it, both the AC/DC Module and the RF Module give you the option to replace the metal interior by an Impedance boundary condition on its surface. This effectively moves all induced fields and currents to the surface of the metal, avoiding the need to resolve its interior.

To learn more about skin depth modeling, see [www.comsol.com/support/knowledgebase/1004](http://www.comsol.com/support/knowledgebase/1004)

## Expand Your Views!

Do you feel that your COMSOL Desktop gets crowded with a lot of information in each view? Double click the window tab to maximize the window you currently work with. Double click again to restore to the original size. Make two plots visible in the same desktop view: Go to the plot group and select Plot Window: New Window in the settings.

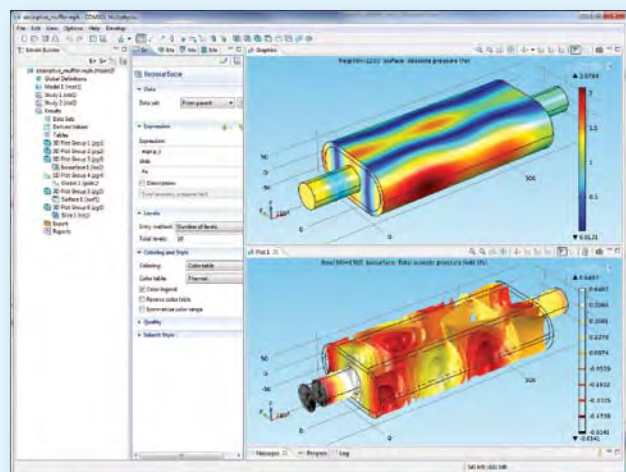
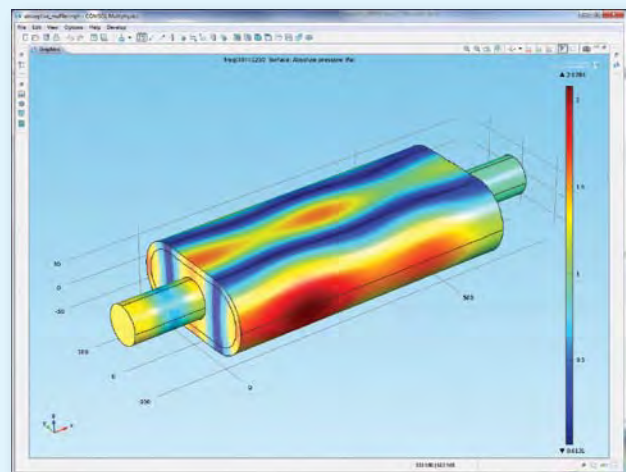



## COMSOL Assists Master Chef in Winning International Competition

BY DAGBJØRN SKIPNES, NOFIMA NORCONSERV AS

Every chef, whether a professional or just a hobby cook, knows the importance of determining how long a dish must be heated and at what temperature. It's not just a matter of avoiding under/overcooking, the dish should reach the table at a pleasing temperature. We also know that food continues to cook when removed from heat; a roast will often stand for 15 minutes or longer after coming out of the oven to allow the meat to settle and the juices to remain in the beef. Indeed, cooking the perfect meal has always been an art — but it's also becoming somewhat of a science. This was discovered by Norwegian master chef Gunnar Hvarnes, who recently won the silver medal at the “culinary olympiads”, the Bocuse d'Or, for his preparation of halibut. Very interestingly, he enlisted our aid in using COMSOL Multiphysics to help him prepare his masterpiece.

### Promoting Local Foods

The project began when the Norwegian Centres of Expertise — Culinology initiated and funded a project to promote halibut for both the local and export markets. They thought it would be a good idea to sponsor a chef in the Bocuse d'Or competition and also to design a project that would encourage a collaboration among research, chefs and culinology to help make food more innovative and tasty. For this, they enlisted the help of Nofima, a research group majority owned by the Ministry of Fisheries with roughly 500 employees who pursue R&D for the aquaculture, fisheries and food industry in Norway.

Chef Hvarnes was working on some ideas for halibut dishes but the results weren't exactly to his liking. His special dish starts with some halibut which is minced and mixed with spices. He then



Prize-winning chef Gunnar Hvarnes (left) and the author (right) in the test kitchen at the Culinary Institute.

takes a halibut filet and rolls it with this mixture. This fish cylinder is then coated with a special bread crumb crust. He started by experimenting with a number of key factors: the diameter of the fish roll, the thickness of the crust, the temperature of the frying oil, cooking time and others.

In the competition, he had to keep the dish warm for 15 minutes before it arrived in front of the judges during which he was preparing side dishes and decorating the plate. In practice, though, he was having trouble determining how to arrive at

the optimum serving temperature at the proper time.

Coincidentally, our facility has a test kitchen where Chef Hvarnes was working, and it's just one floor up from our offices. So he stopped by and asked if we might be able to help him understand what was going on inside the fish roll as he cooked it.

### Heat Not Concentrated at the Exact Center

For this, we set up a relatively simple 2D COMSOL model (Fig. 1). It's impor-

**“We placed thermocouples in the fish and confirmed the hot and cold spots as predicted by the COMSOL model!”**

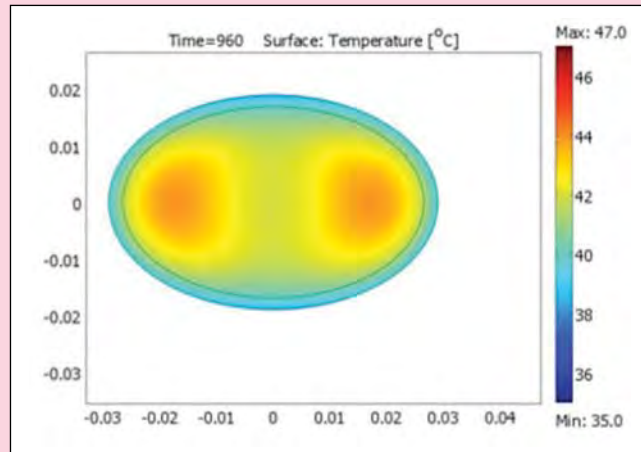

Fig. 1. The award-winning halibut dish from Chef Gunnar Hvarnes and the COMSOL analysis showing the hot spots that emerge during cooking. (photo courtesy of NCE-Culinology, Tom Haga)

tant to note that the fish roll is not a circle but rather an oval; as we discovered, the warmest point is not in the center but rather at two points towards the outside during cooling. Thus, measuring the temperature in the center and basing further steps on this false data continued to lead to less than perfect results. Based on model findings, one of the first things we did was show him where to place his thermometer to determine the maximum temperature inside the fish. We also studied how long the fish should remain in the frying oil, how long it would take to reach the desired temperature in the center (48° C) and how long to let it cool so the heat could distribute itself equally through the dish. In addition, an important factor is that the breadcrumb crust acts as an insulating layer, and our simulation showed how thick this crust should be to meet his requirements.

For this pure convection heating problem we needed only two domains: the fish and the crust. And while the fish fibers exist in a very complex pattern and there is also the minced mixture inside, we found that in the model we could assume that the fish consistency is uniform throughout. Determining the material properties involved some research. I did some initial

measurements to find the heat-transfer coefficient of the fish and also found its specific heat capacity with a differential scanning calorimeter. I was able to find information about its density in a literature search.

Setting up the model took just a couple of hours, and finding the necessary parameters took a day or two. Then we spent roughly three days in the kitchen and lab to verify the model. We placed thermocouples in the fish and confirmed the hot and cold spots as predicted by the COMSOL model.

When setting up the model, Chef Hvarnes told me the maximum temperature at which he could cook the fish and the desired temperature when it was being

served. Together we determined the best size for the fish roll, the thickness of the crust along with how long to cook it and at what temperature.

Having perfected his dish with the help of COMSOL, he then went to Geneva, Switzerland, last June for the Bocuse d'Or competition, which takes place every two years. Working in 18 m<sup>2</sup> contest kitchens set up facing the public, 20 chefs took up the challenge of creating two meals, one using Swiss veal and another using Sterling white halibut, within a certain time limit. With the understanding he gained from the COMSOL model, Chef Hvarnes was able to create a dish that was awarded the silver medal and 9000 euros in prize money. ■

## About the Author

Dagbjørn Skipnes has worked for Nofima Norconserv AS since January 1993. He graduated with a M.Sc. from the Norwegian University of Science and Technology in Trondheim. He has been working in the field of thermal processing of foods and fish-processing technology, and since 1997 Dagbjørn has focused on the minimal processing of convenience fish products and was involved in the establishment of the sous-vide fish processing company Fjordkjøkken AS. Most recently, Dagbjørn has been completing his Ph.D. at the Norwegian University of Life Sciences.





Chris Randles has over 25 years experience in the application software industry. Prior to SpaceClaim, Randles was Entrepreneur-in-Residence at Borealis Ventures. Prior to Borealis, Randles led the management buyout of Mathsoft and served as its Chairman, President and CEO until the company was acquired by PTC (Parametric Technology Corporation). Randles holds Bachelor's and Master's degrees from the University of Oxford, England.

## GUEST EDITORIAL

# 3D Direct Modeling: Removing Bottlenecks in Multiphysics Simulation

BY CHRIS RANGLES, SPACECLAIM PRESIDENT AND CHIEF EXECUTIVE OFFICER

**G**eometry is a critical constituent in almost every multiphysics simulation: representations must be sufficiently accurate for the given problem, possess the appropriate level of detail for pre-processing, and still be easily manipulated for iterative design modifications and optimization. Geometry creation and preparation can be the most labor-intensive stage of the CAE process, and that toil can detract from value-added work such as applying knowledge of materials, physics, and engineering to design problems and interpreting simulation results. We've worked closely with COMSOL and other simulation providers to develop a product, SpaceClaim Engineer, designed to help engineers create concepts and prepare models for multiphysics without the hassles of traditional CAD.

Historically, CAE engineers have possessed limited options for geometry creation and manipulation. Traditionally, engineers would turn to CAD systems designed to create manufacturing documentation. Unfortunately, these systems proved inadequate for many common multiphysics use cases. In particular, the history-based modeling paradigm found in most traditional CAD solutions is, by design, intended to document modeling intent, requiring that operators lock down the models with a combination of constraints, inter-component references, and geometric relationships. The resulting models may only be edited as the CAD us-

ers intended, and therefore stakeholders outside of the core CAD teams often find these models difficult to repurpose, limiting thorough performance assessment and locking-in design intent prior to simulation. Additionally, production CAD geometry often includes features that must be removed before meshing or are unnecessary for the accuracy of a design study, and these features can be problematic to extract. Simply suppressing or removing them can change referenced geometry in unpredictable ways, effectively necessitating that models simplified in feature-based tools be geometrically compared to the originals. Finally, the complexity of most CAD systems required for detailed design can make using them inconvenient for many simulation users.

Recent developments in solid modeling have allowed us to provide a new alternative for geometry creation, simplification, and editing that can often better serve simulation users than the traditional history-based approach to CAD. This technology is typically called "direct modeling" in the CAD industry. Direct modeling uses a fundamentally different paradigm of representing and editing solid models, lends itself well to many CAE applications, and can remove geometry bottlenecks from simulation workflows. SpaceClaim combines direct modeling with special-purpose tools designed for simulation users' unique needs.

De-featuring is a routine activity when working with existing data. Many features found in CAD models, such as rounds, holes, small features, and manufacturing marks do not materially affect simulation results, yet can increase mesh sizes and lengthen solve times. SpaceClaim's unique feature recognition capabilities can often automatically detect these features and remove them, because such de-featuring is a critical step during the normal editing process.

SpaceClaim can also add parameters to otherwise static geometry imported from CAD systems. Engineers can add different sets of parameters to models to generate design studies and closed-loop optimization with simulation results. This optimized geometry can be returned to CAD as the specification for further detailed design.

CAE engineers may find that direct modeling can help them navigate the engineering solution space more effectively, converging on optimal designs more quickly. When performing simulations on existing CAD data, direct modeling can accelerate geometry preparation, model validation, and optimization and better communicate with the CAD team. It can ultimately create a more collaborative engineering environment, where more stakeholders can effectively converse in 3D. At SpaceClaim, we're pleased to be making CAE-focused direct modeling available to COMSOL users. ■